

# OPERATOR'S MANUAL

# NM2328A-X

SPECIFICATIONS, SERVICE KITS, GENERAL INFORMATION, TROUBLESHOOTING

INCLUDE MANUALS: 66066-X LOWER PUMP END (PN 97999-770), 66913 AIR MOTOR (PN 97999-748) & S-632 GENERAL INFORMATION MANUAL (PN 97999-624).

RELEASED: 10-21-97

REVISED: 6-1-10

(REV. C)

**3" AIR MOTOR**  
**28:1 RATIO**  
**3" STROKE**

## NM2328A-11-X11

### TWO BALL PUMP SERIES

STAINLESS STEEL



**READ THIS MANUAL CAREFULLY BEFORE INSTALLING, OPERATING OR SERVICING THIS EQUIPMENT.**

It is the responsibility of the employer to place this information in the hands of the operator. Keep for future reference.

### SERVICE KITS

- Use only genuine ARO replacement parts to assure compatible pressure rating and longest service life.
- **637316** for repair of Air Motor section.
- **637006-1** for repair of 66066-1 lower pump section.
- **637006-2** for repair of 66066-2 lower pump section.
- **637006-3** for repair of 66066-3 lower pump section.
- **637007** for replacement of foot valve assembly.

### SPECIFICATIONS

<b>Model Series</b> (refer to option chart) . . .	NM2328A-11-X11
<b>Type</b> . . . . .	Air Operated, Two Ball
<b>Ratio</b> . . . . .	28:1
<b>Air Motor</b> . . . . .	66914
<b>Motor Repair Kit</b> . . . . .	637316
<b>Motor Diameter</b> . . . . .	3" (7.62 cm)
<b>Stroke (Double Acting)</b> . . . . .	3" (7.62 cm)
<b>Air Inlet</b> . . . . .	1/4 - 18 N.P.T.F. (female)
<b>Lower Pump End Series</b>	
NM2328A-11-311 . . . . .	66066-1
NM2328A-11-G11 . . . . .	66066-2
NM2328A-11-S11 . . . . .	66066-3
<b>Material Inlet</b> . . . . .	1/2 - 14 N.P.T.F. - 1 (female)
<b>Material Outlet</b> . . . . .	1/4 - 18 N.P.S.M. (male)

### PERFORMANCE

<b>Air Inlet Pressure Range</b> . . . . .	0 - 150 p.s.i. (0 - 10.3 bar)
<b>Fluid Pressure Range</b> . . . . .	0 - 4200 p.s.i. (0 - 289.7 bar)
<b>Max. Rec'd Cycles / Minute</b> . . . . .	125
<b>Displacement In<sup>3</sup> Per Cycle</b> . . . . .	1.47
<b>Volume / Cycle</b> . . . . .	0.81 oz. (.45 ml)
<b>Cycles Per Gallon</b> . . . . .	157.5
<b>Flow @ 60 Cycles / Minute</b> . . . . .	0.38 g.p.m. (1.44 l.p.m.)
<b>Noise Level @ 100 p.s.i.</b> . . . . .	85 db(A) *
<b>Accessories Available</b> . . . . .	61113 Wall Mount Bracket
	66073-1 Air Line Connection Kit

\* The pump sound pressure level has been updated to an Equivalent Continuous Sound Level (L<sub>Aeq</sub>) to meet the intent of ANSI S1. 13-1971, CAGI-PNEUROP S5.1 using four microphone locations.

### PUMP DATA

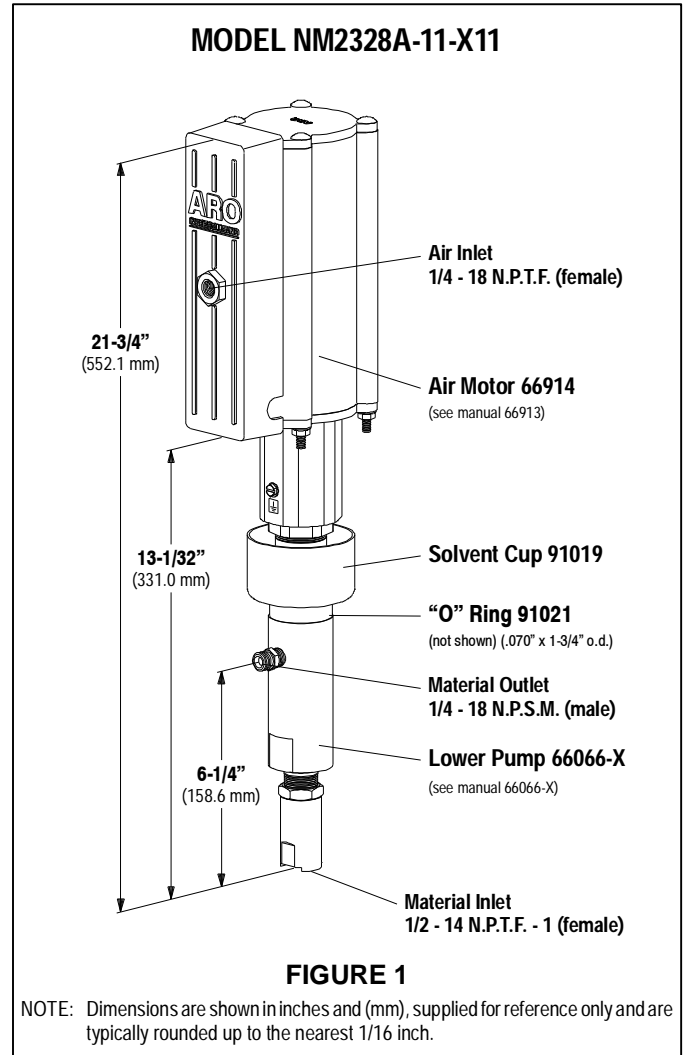

### IMPORTANT

This is one of the four documents which support the pump. Replacement copies of these forms are available upon request.

- = NM2328A-X MODEL OPERATOR'S MANUAL
- GENERAL INFORMATION - INDUSTRIAL PISTON PUMPS
- 66066-X LOWER PUMP END OPERATOR'S MANUAL
- 66913 AIR MOTOR OPERATOR'S MANUAL

**PUMP OPTION DESCRIPTION CHART**

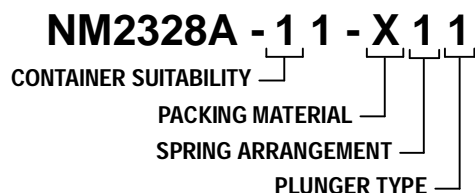

**CONTAINER SUITABILITY**

1 UNIVERSAL (STUB)

**SPRING ARRANGEMENT**

1 COIL

**PLUNGER TYPE**

1 440 SERIES STAINLESS STEEL

**PACKING MATERIAL**

3 GLASS FILLED PTFE (UPPER AND LOWER)

G UHMW-PE / LEATHER STAG'D (UPPER AND LOWER)

S UHMW-PE / GLASS FILLED PTFE STAG'D (UPPER AND LOWER)

**GENERAL DESCRIPTION**

**⚠ WARNING HAZARDOUS PRESSURE.** Do not exceed maximum operating pressure of 4200 p.s.i. (289.7 bar) at 150 p.s.i. (10.3 bar) inlet air pressure.

**PUMP RATIO X  
INLET PRESSURE TO PUMP MOTOR = MAXIMUM PUMP  
FLUID PRESSURE**

Pump ratio is an expression of the relationship between the pump motor area and the lower pump end area. EXAMPLE: When 150 p.s.i. (10.3 bar) inlet pressure is supplied to the motor of a 28:1 ratio pump it will develop a maximum of 4200 p.s.i. (289.7 bar) fluid pressure (at no flow) - as the fluid control is opened, the flow rate will increase as the motor cycle rate increases to keep up with the demand.

**⚠ WARNING** Refer to general information sheet for additional safety precautions and important information.

- The two-ball design provides for easy priming of the lower foot valve. The double acting feature is standard in all ARO industrial pumps. Material is delivered to the pump discharge outlet on both the up and down stroke.
- The motor is connected to the lower pump end with a spacer tube and solvent cup. This allows for lubrication of the upper packing gland and to prevent air motor contamination because of normal wear and eventual leakage through the material packing gland.

**TROUBLE SHOOTING**

Pump problems can occur in either the Air Motor Section or the Lower Pump End Section. Use these basic guidelines to help determine which section is affected. Be sure to eliminate any possible non-pump problems before suspecting pump malfunction.

**Pump will not cycle.**

- No pressure to the motor. See motor manual.
- Restricted return lines. Clean obstruction.
- Damaged motor. Service motor

**No material at the outlet (pump continually cycles).**

- Check the material supply, disconnect or shut off the air supply and replenish the material, reconnect.

**Material on one stroke only (fast downstroke).**

- The lower check may not be seating in the foot valve (see lower pump disassembly). Remove the check from the foot valve, clean and inspect the valve seat area. If check or foot valve are damaged, replace.

**Material on one stroke only (fast upstroke).**

- The middle packings may be worn (see lower pump disassembly). Replace the seals as necessary.

**Material leakage out of the solvent cup or material appears on the pump plunger rod.**

- Tighten the solvent cup until leakage discontinues. If this procedure does not aid in stopping the leakage problem, the upper packings may be worn (see lower pump disassembly). Replace the seals as necessary.

**PUMP CONNECTION - UPPER / LOWER**

**NOTE: All threads are right hand.**

1. Loosen (90027) lock nut and unscrew entire pump from the air motor. This will expose (94786) connecting pin (see figure 2).
2. Remove (Y15-21-S) cotter pin and (94786) connecting pin to release plunger from piston rod.

**PUMP CONNECTOR DETAIL**

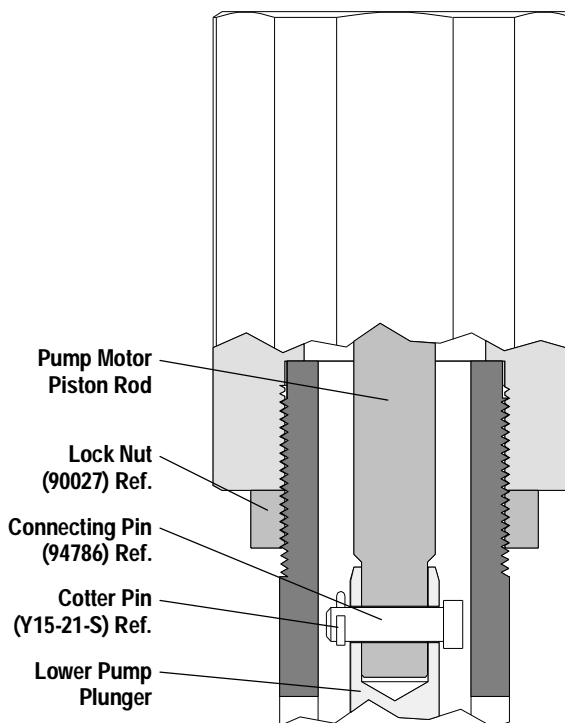

**FIGURE 2**

**REASSEMBLY**

1. Assemble (90267) plunger to air motor rod, aligning through holes.
2. Assemble (94786) connecting pin through hole, securing plunger.
3. Assemble (Y15-21-S) cotter pin through connecting pin.
4. Screw the lower pump assembly to the air motor.
5. Screw (90027) lock nut against air motor base and tighten.