

SALES & ENGINEERING DATA

PM30A-CSS-XXX-C02 & PM30S-CSS-XXX-C02 3" METALLIC DIAPHRAGM PUMP

RATIO SERIES: **1:1**

FLUID P.S.I. RANGE: **20 - 120**

RELEASED: 2-14-05
REVISED: 6-10-10
(REV. 03) S-1346

DIMENSIONAL DATA

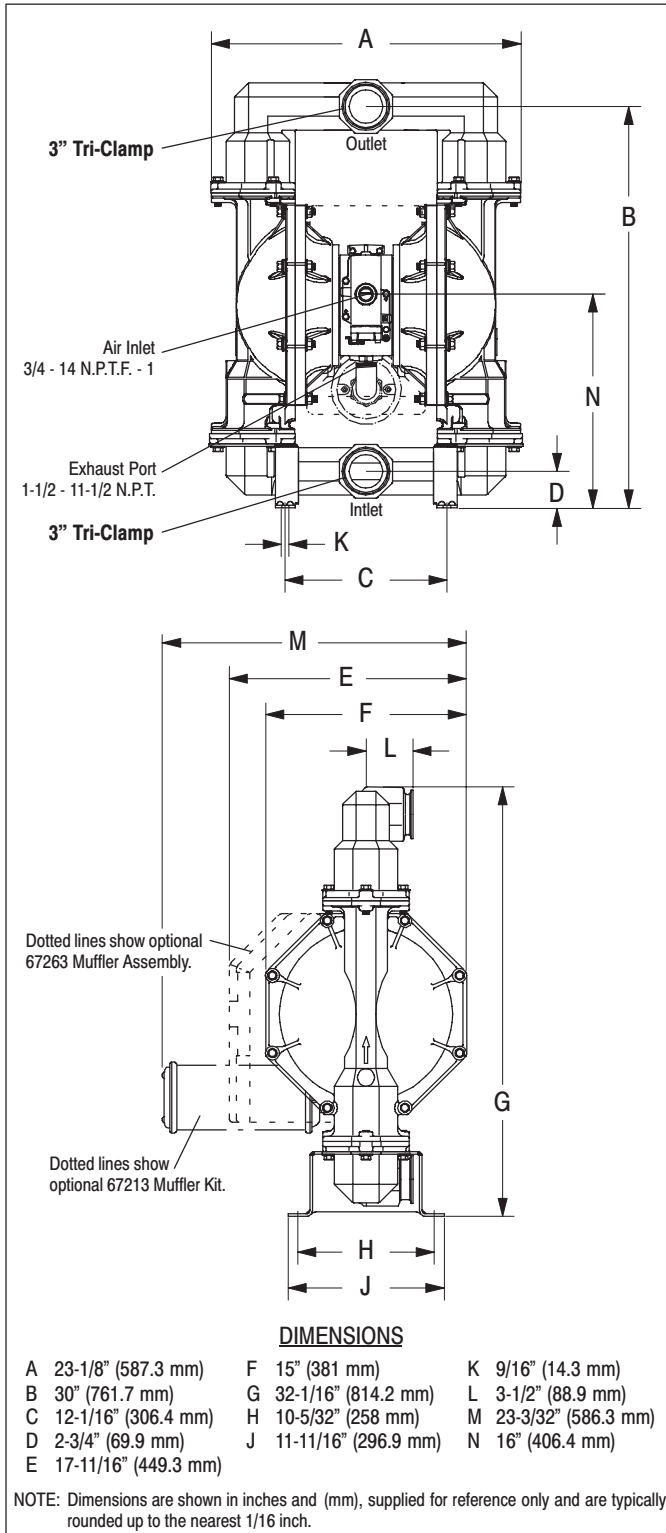

SPECIFICATIONS

CONSTRUCTION

Model Series	PM30A-CSS-XXX-C02
	PM30S-CSS-XXX-C02
Pump Type	Metallic, Air Operated, Double Diaphragm
Ratio	1:1
Material Inlet / Outlet	3" Tri-Clamp
Air Inlet (female)	3/4 - 14 N.P.T.F. - 1
Air Exhaust (female)	1-1/2 - 11-1/2 N.P.T.
Weight	PM30A-CSS-XXX-C02 . . . 227.5 lbs (103.2 kgs)
	PM30S-CSS-XXX-C02 . . . 267.2 lbs (121.2 kgs)
Air Section Service Kit	637421
Major Air Valve Assembly	637374-X
Fluid Section Service Kit	637303-XX

PM30X-CSS- X X X -C02
637303 - X X
 Diaphragm Material
 Ball Material

EXAMPLE: Model #PM30S-CSS-SAA-C02
 Fluid Section Service Kit is 637303-AA

PERFORMANCE

Air Inlet Pressure Range	20 - 120 p.s.i. (1.4 - 8.3 bar)
Maximum Material Inlet Pressure	10 p.s.i. (0.69 bar)
Fluid Outlet Pressure Range	20 - 120 p.s.i. (1.4 - 8.3 bar)
Maximum Flow Rate	237 g.p.m. (897 l.p.m.)
flooded inlet	275 g.p.m. (1,041 l.p.m.)
Maximum Particle Size	3/8" dia. (9.5 mm)
Maximum Temperature Limits (diaphragm / ball / seal material)	
E.P.R.	-60 to 280° F (-51 to 138° C)
Santoprene	-40 to 225° F (-40 to 107° C)
PTFE	40 to 225° F (4 to 107° C)
Displacement / Cycle @ 100 p.s.i.	2.8 gal. (10.6 lit.)
Noise Level @ 70 p.s.i. - 50 c.p.m.①	83.0 db(A)②

Notes:

- ① Tested with 67263 muffler assembly installed.
- ② The pump sound pressure level has been updated to an Equivalent Continuous Sound Level (L_{Aeq}) to meet the intent of ANSI S1. 13-1971, CAGI-PNEUROP S5.1 using four microphone locations.

ACCESSORIES:

- 66109 Air line Connection Kit
- 67213 Muffler Kit
- 67263 Continuous Muffler
- 94117 Int. Muffler

PERFORMANCE CURVES

PM30A-CSS-XXX-C02 / PM30S-CSS-XXX-C02 3" METALLIC DIAPHRAGM PUMP

