

# SALES & ENGINEERING DATA

RATIO SERIES: **1:1**

FLUID P.S.I. RANGE: **20 - 120**

## PM30R-CSS-XXX-C02 3" METALLIC DIAPHRAGM PUMP

RELEASED: 2-16-05  
REVISED: 6-10-10  
(REV. 03) S-1347

### DIMENSIONAL DATA

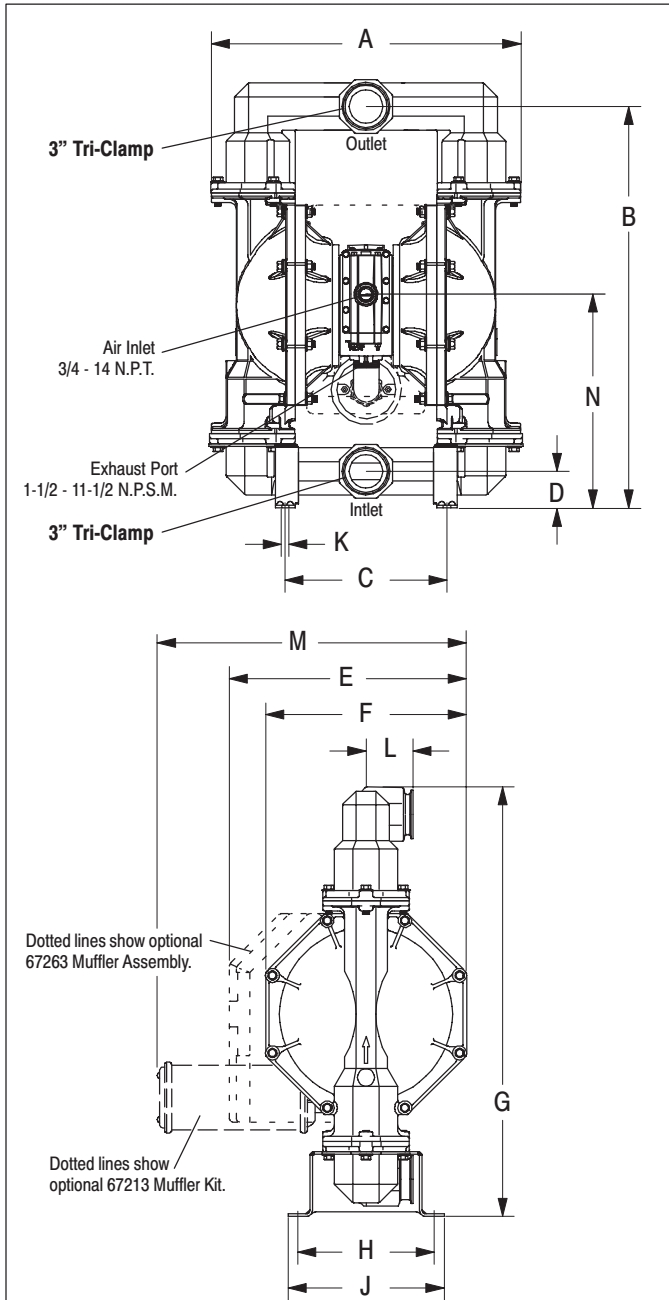

### DIMENSIONS

A 23-1/8" (587.3 mm)	F 15" (381 mm)	K 9/16" (14.3 mm)
B 30" (761.7 mm)	G 32" (812.5 mm)	L 3-1/2" (88.9 mm)
C 12-1/16" (306.4 mm)	H 10-5/32" (258 mm)	M 23-3/32" (586.3 mm)
D 2-3/4" (69.9 mm)	J 11-11/16" (296.9 mm)	N 16" (406.4 mm)
E 17-11/16" (449.3 mm)		

NOTE: Dimensions are shown in inches and (mm), supplied for reference only and are typically rounded up to the nearest 1/16 inch.

### SPECIFICATIONS

#### CONSTRUCTION

Model Series	PM30R-CSS-XXX-C02
Pump Type	Metallic, Air Operated, Double Diaphragm
Ratio	1:1
Material Inlet / Outlet	3" Tri-Clamp
Air Inlet (female)	3/4 - 14 N.P.T.
Air Exhaust (female)	1-1/2 - 11-1/2 N.P.S.M.
Weight	253.3 lbs (114.9 kgs)
Air Section Service Kit	637369
Major Air Valve Assembly	637374
Fluid Section Service Kit	637303-XX

PM30R-CSS- X   -C02

637303 -

Diaphragm Material  
Ball Material

EXAMPLE: Model #PM30R-CSS-SAA-C02

Fluid Section Service Kit is 637303-AA

#### PERFORMANCE

Air Inlet Pressure Range	20 - 120 p.s.i. (1.4 - 8.3 bar)
Maximum Material Inlet Pressure	10 p.s.i. (0.69 bar)
Fluid Outlet Pressure Range	20 - 120 p.s.i. (1.4 - 8.3 bar)
Maximum Flow Rate	237 g.p.m. (897 l.p.m.)
flooded inlet	275 g.p.m. (1,041 l.p.m.)
Maximum Particle Size	3/8" dia. (9.5 mm)
Maximum Temperature Limits (diaphragm / ball / seal material)	
E.P.R.	-60° to 280° F (-51° to 138° C)
Nitrile	10° to 180° F (-12° to 82° C)
Polypropylene	35° to 150° F (2° to 66° C)
Santoprene	-40° to 225° F (-40° to 107° C)
PTFE	40° to 225° F (4° to 107° C)
Displacement / Cycle @ 100 p.s.i.	2.8 gal. (10.6 lit.)
Noise Level @ 70 p.s.i. - 50 c.p.m.①	83.0 db(A)②

#### Notes:

① Tested with 67263 muffler assembly installed.

② The pump sound pressure level has been updated to an Equivalent Continuous Sound Level (L<sub>Aeq</sub>) to meet the intent of ANSI S1. 13-1971, CAGI-PNEUROP S5.1 using four microphone locations.

#### ACCESSORIES:

- 66109 Air Line Connection Kit
- 67213 Muffler Kit
- 67263 Continuous Muffler
- 94117 Int. Muffler

**PERFORMANCE CURVES**

**PM30R-CSS-XXX-C02 3" METALLIC DIAPHRAGM PUMP**

