

SALES & ENGINEERING DATA

RATIO SERIES: **1:1**

FLUID P.S.I. RANGE: **20 - 120**

6662A3-XXX-C THRU 6662B4-XXX-C

2" NON-METALLIC DIAPHRAGM PUMP

RELEASED: 1-31-97
 REVISED: 3-2-06
 (REV. 03) S-877

DIMENSIONAL DATA

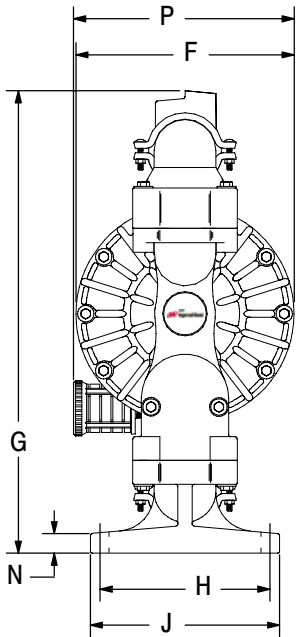
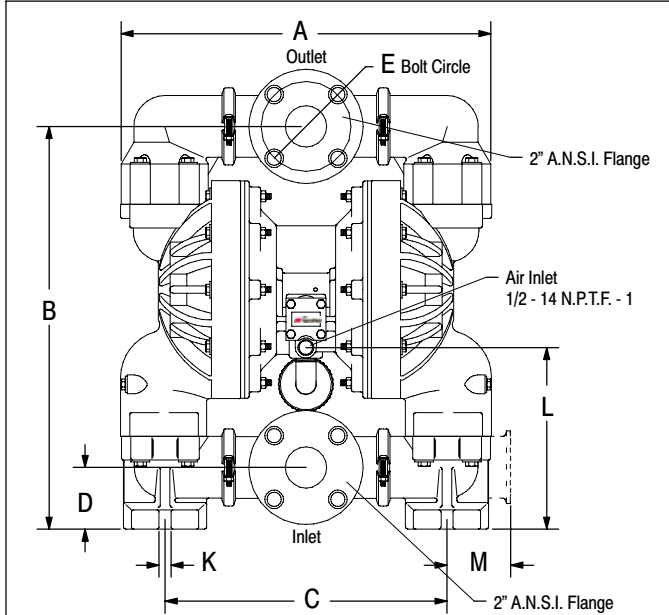

DIMENSIONS

A - 19-3/4" (501 mm)	F - 11-9/16" (293.5 mm)	L - 9-5/8" (244.3 mm)
B - 21-1/2" (545.0 mm)	G - 24-5/8" (625.3 mm)	M - 3-3/8" (85.7 mm)
C - 14-15/16" (379.4 mm)	H - 8-11/16" (220.4 mm)	N - 1-1/16" (26.2 mm)
D - 3-5/16" (83.2 mm)	J - 10-1/16" (254.8 mm)	P - 11-11/16" (296.7 mm)
E - 4.773" (121.2 mm)	K - 5/8" (15.9 mm)	

NOTE: Dimensions are shown in inches and (mm), supplied for reference only and are typically rounded up to the nearest 1/16 inch.

SPECIFICATIONS

CONSTRUCTION

Model Series	6662A3-XXX-C thru 6662B4-XXX-C
Pump Type	Non-Metallic, Air Operated, Double Diaphragm
Ratio	1:1
Material Inlet / Outlet	2" A.N.S.I. Class 150 Flange
Air Inlet (female)	1/2 - 14 N.P.T.F. - 1
Air Exhaust (female)	3/4 - 14 N.P.T.F. - 1
Weight	6662A3-XXX-C 62 lbs (28.1 kgs) 6662A4-XXX-C 92 lbs (41.7 kgs) 6662B3-XXX-C 85 lbs (38.6 kgs) 6662B4-XXX-C 115 lbs (52.2 kgs)
Air Section Service Kit	637118-C
Fluid Section Service Kit	637165-XX

6662A3 - X X X - C
637165 - X X X

Diaphragm Material
 Ball Material

EXAMPLE: Model 6662A3-344-C
 Fluid Section Service Kit is 637165-44

PERFORMANCE

Air Inlet Pressure Range	20 - 120 p.s.i. (1.4 - 8.3 bar)
Fluid Pressure Range	20 - 120 p.s.i. (1.4 - 8.3 bar)
Maximum Material Inlet Pressure	10 p.s.i. (0.69 bar)
Maximum Flow Rate (flooded inlet)	145 g.p.m. (548.8 l.p.m.)
Maximum Particle Size	1/4" dia. (6.4 mm)
Maximum Temperature Limits (diaphragm / ball / seal material)	
E.P.R.	-60° to 280° F (-51° to 138° C)
Hytrek	-20° to 150° F (-29° to 66° C)
Neoprene	0° to 200° F (-18° to 93° C)
Nitrile	10° to 180° F (-12° to 82° C)
Polypropylene	35° to 150° F (2° to 66° C)
Polyurethane	10° to 150° F (-12° to 66° C)
PVDF (Kynar)	10° to 200° F (-12° to 93° C)
Santoprene	-40° to 225° F (-40° to 107° C)
T.F.E. (Teflon)	40° to 225° F (4° to 107° C)
Viton	-40° to 350° F (-40° to 177° C)
Displacement / Cycle @ 100 p.s.i.	0.72 gal. (2.7 lit.)
Noise Level @ 70 p.s.i. - 60 c.p.m.①	77.7 db(A)②

Notes:

- ① Tested with 93139 muffler installed.
- ② The pump sound pressure level has been updated to an Equivalent Continuous Sound Level (L_{Aeq}) to meet the intent of ANSI S1. 13-1971, CAGI-PNEUROPS S5.1 using four microphone locations.

ACCESSORIES:

- 65010 Neoprene "O" Ring Air Motor Kit
- 65764 Viton "O" Ring Air Motor Kit
- 66084-1 Air Line Connection Kit

PERFORMANCE CURVES

6662XX-XXX-C 2" NON-METALLIC DIAPHRAGM PUMP

