

# SALES & ENGINEERING DATA

RATIO SERIES:	<b>65:1</b>
FLUID P.S.I. RANGE:	<b>1950 - 5850</b>

**650989-XXD**

## EXTRUSION PUMP

RELEASED: 6-21-02  
 REVISED: S-1215

### DIMENSIONAL DATA

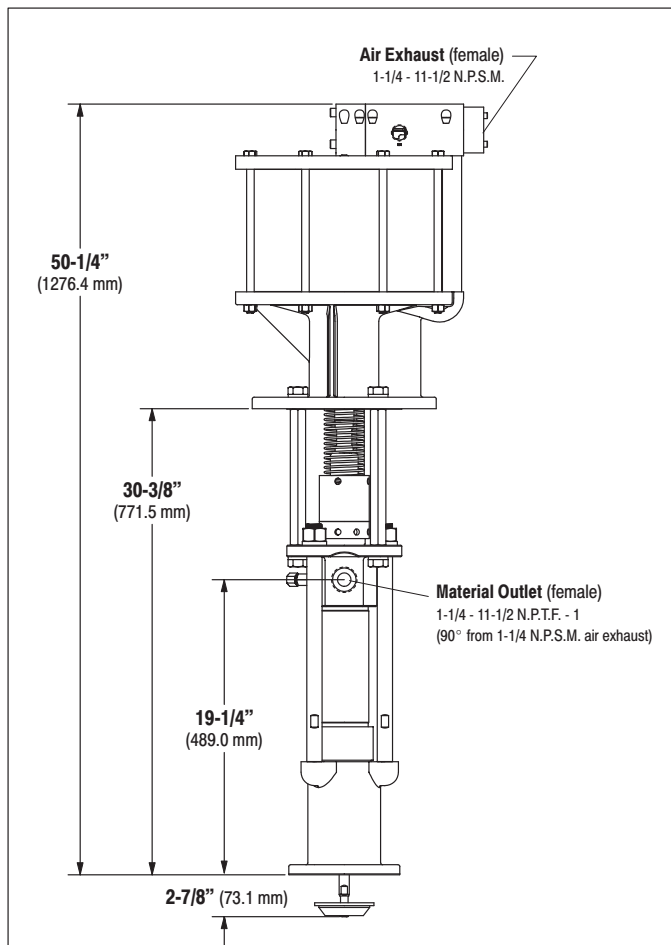

#### BOTTOM VIEW

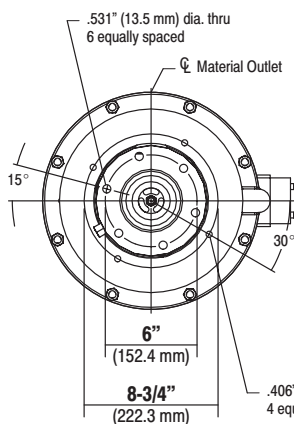

#### TOP VIEW

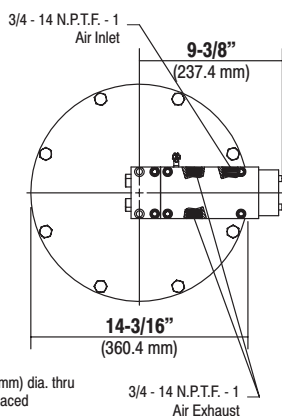

NOTE: Dimensions are shown in inches and (mm), supplied for reference only and are typically rounded up to the nearest 1/16 inch.

### SPECIFICATIONS

#### CONSTRUCTION

<b>Model Series</b> (refer to option chart)	650989-XXD
<b>Pump Type</b>	Air Operated, Extrusion, Double Acting Pump
<b>Ratio</b>	65:1
<b>Air Motor</b>	66506-B
<b>Motor Repair Kit</b>	637112
<b>Motor Diameter</b>	12" (304.8 mm)
<b>Stroke</b>	6" (152.4 mm)
<b>Air Inlet (female)</b>	3/4 - 14 N.P.T.F. - 1
<b>Air Exhaust (female)</b>	1-1/4 - 11-1/2 N.P.S.M.
<b>Lower Pump End Series</b>	67300-XXD
<b>Lower Pump Repair Kit</b>	637348-XXD

#### Packing Options:

- C - UHMW-PE
- J - Polyurethane upper • UHMW-PE lower

**Material Outlet (female)** ..... 1-1/4 - 11-1/2 N.P.T.F. - 1

#### MATERIALS OF CONSTRUCTION

<b>Outlet Body</b>	Carbon Steel, Nickel plated
<b>Cylinder</b>	Carbon Steel, Nickel Plated
<b>Plunger</b>	17-4 Stainless Steel, Chrome plated
<b>Upper Check</b>	440 Stainless Steel
<b>Upper Seat</b>	440 Stainless Steel
<b>Lower Check</b>	440 Stainless Steel
<b>Lower Seat</b>	440 Stainless Steel
<b>Inlet Body</b>	Ductile Iron, Nickel plated
<b>Weight</b>	165 lbs (74.8 kgs)

#### PERFORMANCE

<b>Air Inlet Pressure Range</b>	30 - 90 p.s.i. (2.1 - 6.2 bar)
<b>Fluid Pressure Range</b>	1950 - 5850 p.s.i. (134.5 - 403.4 bar)
<b>Max. recommended cycles / minute</b>	70
<b>Displacement Per Cycle</b>	20.0 in <sup>3</sup> (327.8 cm <sup>3</sup> )
<b>Volume / Cycle</b>	11.08 oz. (327.6 ml)
<b>Noise Level @ 60 p.s.i. - 40 c.p.m.</b>	89.8 db(A) <sup>①</sup>

<sup>①</sup> Tested with 66718 Muffler installed. The pump sound pressure level has been updated to an Equivalent Continuous Sound Level (L<sub>Aeq</sub>) to meet the intent of ANSI S1.13-1971, CAGI-PNEUROP S5.1 using four microphone locations.

#### ACCESSORIES:

- 66542 Wall Mount Bracket
- 65139 Floor Mount
- 66718 Silencer



PERFORMANCE CURVES

