

SALES & ENGINEERING DATA

RATIO SERIES: **30:1**

FLUID P.S.I. RANGE: **900 - 3250**

650971-XXE-C EXTRUSION PUMP

RELEASED: 9-20-01
 REVISED: 5-26-10
 (REV. 02) S-1028

DIMENSIONAL DATA

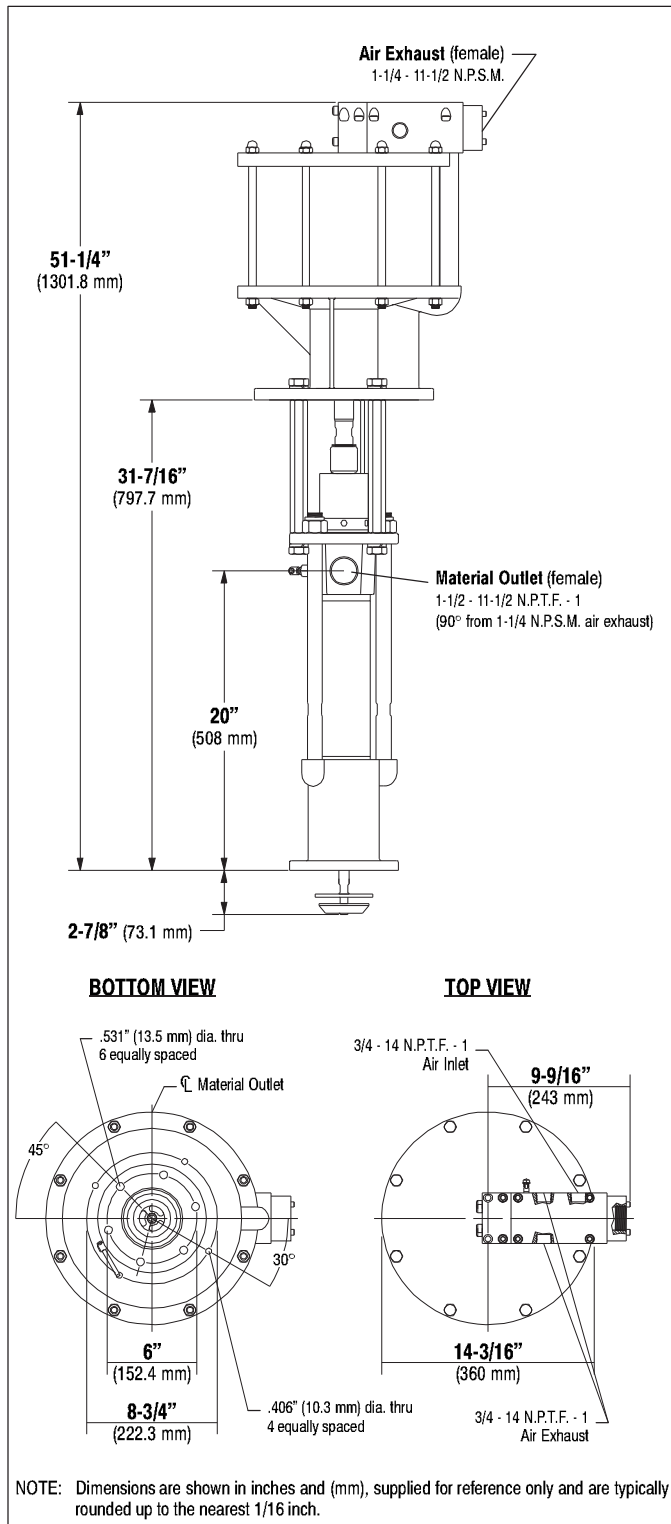

SPECIFICATIONS

CONSTRUCTION

Model Series (refer to option chart)	650971-XXE-C
Pump Type	Air Operated, Extrusion, Double Acting Pump
Ratio	30:1
Air Motor	66506-B
Motor Repair Kit	637112
Motor Diameter	12" (304.8 mm)
Stroke	6" (152.4 mm)
Air Inlet (female)	3/4 - 14 N.P.T.F. - 1
Air Exhaust (female)	1-1/4 - 11-1/2 N.P.S.M.
Lower Pump End Series	66236-XXE-B
Lower Pump Repair Kit	637128-XX4-B
Packing Options:	

3 - Glass Filled PTFE
C - UHMW-PE
F - UHMW-PE / Leather staggered upper • UHMW-PE lower
J - Polyurethane upper • UHMW-PE lower
P - UHMW-PE / Glass Filled PTFE staggered upper • UHMW-PE lower
R - Glass Filled PTFE / UHMW-PE staggered upper • Glass Filled PTFE lower

Material Outlet (female) 1-1/2 - 11-1/2 N.P.T.F. - 1

MATERIALS OF CONSTRUCTION

Outlet Body	Ductile Iron, Nickel plated
Cylinder	Carbon Steel, Nickel plated
Plunger	Carbon Steel, Chrome plated
Upper Check	440 Stainless Steel
Upper Seat	440 Stainless Steel
Lower Check	440 Stainless Steel
Lower Seat	440 Stainless Steel
Inlet Body	Ductile Iron, Nickel plated
Weight	140 lbs (63.5 kgs)

PERFORMANCE

Air Inlet Pressure Range	30 - 90 p.s.i. (2.1 - 6.2 bar)
Fluid Pressure Range	900 - 3250 p.s.i. (62.1 - 224.1 bar)
Maximum Rec'd Cycles / Minute	70
Displacement In³ Per Cycle	40.4
Volume / Cycle	22.4 oz. (661.8 ml)
Cycles Per Gallon	5.7
Flow @ 70 Cycles / Minute	12.2 g.p.m. (46.3 l.p.m.)
Noise Level @ 60 p.s.i. - 40 c.p.m.	89.8 db(A) ^①

① Tested with 66718 Muffler installed. The pump sound pressure level has been updated to an Equivalent Continuous Sound Level (L_{Aeq}) to meet the intent of ANSI S1.13-1971, CAGI-PNEUROP S5.1 using four microphone locations.

ACCESSORIES:

- 66542 Wall Mount Bracket
- 65139 Floor Mount
- 66718 Silencer

PERFORMANCE CURVES

