

OPERATOR'S MANUAL

650950-X

INCLUDING: SPECIFICATIONS, SERVICE KITS, GENERAL INFORMATION, TROUBLESHOOTING.
 INCLUDE MANUALS: 6720X-X Lower Pump End (pn 97999-788), 67147-B Hydraulic Motor (pn 97999-1219) &
 S-632 General Information Manual (pn 97999-624)

RELEASED: 8-28-98
 REVISED: 11-13-06
 (REV. E)

2.062 SQ." HYDRAULIC MOTOR
0.2:1 RATIO
5.75" STROKE

650950-X4X
FOUR BALL PUMP SERIES
 300 SERIES STAINLESS STEEL



**READ THIS MANUAL CAREFULLY BEFORE INSTALLING,
 OPERATING OR SERVICING THIS EQUIPMENT.**

It is the responsibility of the employer to place this information in the hands of the operator. Keep for future reference.

SERVICE KITS

- Use only genuine ARO® replacement parts to assure compatible pressure rating and longest service life.
- **637449** for repair of hydraulic motor section.
- **637318-X4B** for repair of lower pump section. Refer to the chart on page 2 for description of -X4X options.

SPECIFICATIONS

Model Series (Refer to option chart)	650950-X4X
Type	Hydraulically Operated, Four Ball
Ratio	0.2:1
Hydraulic Motor	67147-B
Motor Repair Kit	637449
Motor Size	2.062 sq." (13.3 sq. cm)
Stroke	5.75" (14.6 cm)
Hydraulic Inlet (female)	3/8 - 18 N.P.T.F. - 2
Hydraulic Return (female)	1/2 - 14 N.P.T.F. - 2
Lower Pump End Series	67201-X4X
Lower Pump Repair Kit	637318-X4B
Material Inlet (female)	1-1/2 - 11-1/2 N.P.T.F. - 1
(male)	2 - 11-1/2 P.T.F. SAE Spec Short
Material Outlet (female)	1 - 11-1/2 N.P.T.F. - 1
Weight	72 lbs (32.7 kgs)

PERFORMANCE

Hydraulic Inlet Pressure Range	50 - 1200 p.s.i. (3.4 - 82.8 bar)
Fluid Pressure Range	10 - 278 p.s.i. (0.69 - 19.2 bar)
Required H-power @ 50 c.p.m.	3.2 @ 1200 p.s.i. (82.8 bar)
Hydraulic flow required @ 50 c.p.m.	4.9 g.p.m. (18.5 l.p.m.)
Maximum rec'd Cycles / Minute	50
Displacement In³ Per Cycle	103.6
Volume / Cycle	57.4 oz. (1697.2 ml)
Cycles Per Gallon	2.23
Flow @ 50 Cycles / Minute	22.4 g.p.m. (84.9 l.p.m.)
Noise Level	N/A
Maximum Temperature Limit	130° F (54° C)

PUMP DATA

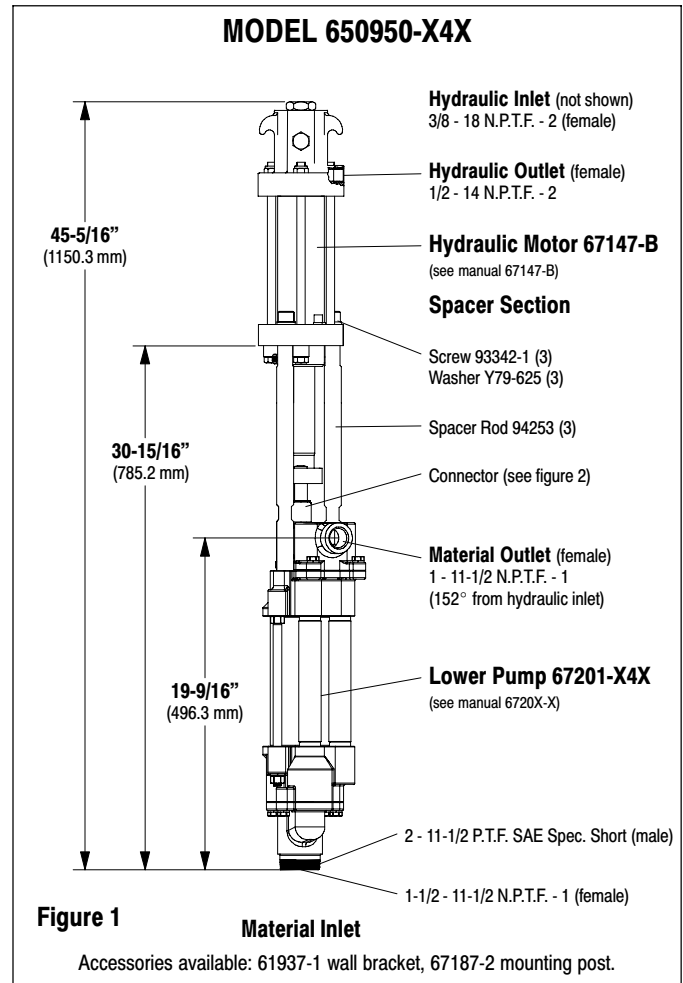

IMPORTANT

This is one of the four documents which support the pump. Replacement copies of these forms are available upon request.

- 650950-X Model Operator's Manual (pn 97999-795)
- S-632 General Information - Industrial Piston Pumps (pn 97999-624)
- 6720X-X Lower Pump End Operator's Manual (pn 97999-788)
- 67147-B Hydraulic Motor Operator's Manual (pn 97999-1219)

PUMP OPTION DESCRIPTION CHART

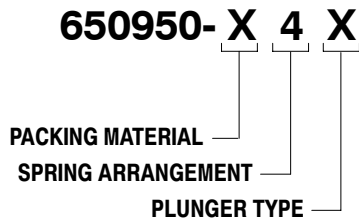

PACKING MATERIAL (packings are upper and lower unless noted)

- 7 Glass filled Teflon (upper) / Virgin Teflon (lower)
- C UHMW-PE
- F UHMW-PE / Leather staggered (upper) / UHMW-PE (lower)
- P UHMW-PE / Teflon staggered (upper) / UHMW-PE (lower)
- R Teflon / UHMW-PE staggered (upper) / Virgin Teflon (lower)

SPRING ARRANGEMENT

- 4 Multiple wave spring

PLUNGER TYPE

- B Hardened stainless steel with ceramic coating
- 3 Hardened stainless steel with hard chrome plating

GENERAL DESCRIPTION

⚠ WARNING HAZARDOUS PRESSURE. Do not exceed maximum operating pressure of 278 p.s.i. (19.2 bar) at 1200 p.s.i. (82.8 bar) inlet hydraulic pressure.

<p>PUMP RATIO X INLET PRESSURE TO PUMP MOTOR = MAXIMUM PUMP FLUID PRESSURE</p> <p>Pump ratio is an expression of the relationship between the pump motor area and the lower pump end area. EXAMPLE: When 150 p.s.i. (10.3 bar) inlet pressure is supplied to the motor of a 5:1 ratio pump, it will develop a maximum of 750 p.s.i. (51.7 bar) fluid pressure (at no flow) – as the fluid control is opened, the flow rate will increase as the motor cycle rate increases to keep up with the demand.</p>

⚠ WARNING Refer to general information sheet for additional safety precautions and important information.

- The four-ball pumps are primarily designed for the high volume transfer of light and medium viscosity fluids. Stainless steel construction offers compatibility with a wide range of fluids. The lower pump is designed for easy priming and the double acting feature is standard in all ARO industrial pumps. Material is delivered to the pump discharge outlet on both the up and down stroke.
- The motor is connected to the lower pump end by a spacer section. This allows for lubrication of the upper packing gland and prevents motor contamination because of normal wear and eventual leakage through the material packing gland. Be sure the solvent cup is adequately filled with lubricant to protect the upper packings and insure longest service life.

TROUBLE SHOOTING

Pump problems can occur in either the hydraulic motor section or the lower pump end section. Use these basic guidelines to help determine which section is affected.

If the pump will not cycle.

- Be certain to first check for non-pump problems including kinked, restrictive or plugged inlet / outlet hose or dispensing device. Depressurize the pump system and clean out any obstructions in the inlet / outlet material lines.
- Refer to the motor manual for trouble shooting if the pump does not cycle and / or hydraulic fluid leaks from the hydraulic motor.

If the pump cycles but does not deliver material.

- Refer to the lower pump end manual for further trouble shooting.

PUMP CONNECTION - UPPER / LOWER

NOTE: All threads are right hand.

1. Lay the pump assembly on a workbench.
2. Remove the three screws and washers from the three spacer rods (see figure 1).
3. Pull the hydraulic motor from the lower pump end until motor piston rod is in the “down” position and lower pump end rod is in “up” position.
4. Using e-ring pliers, slide the retaining ring up far enough to allow the sleeve to move upward and release the two connectors (see figure 2).

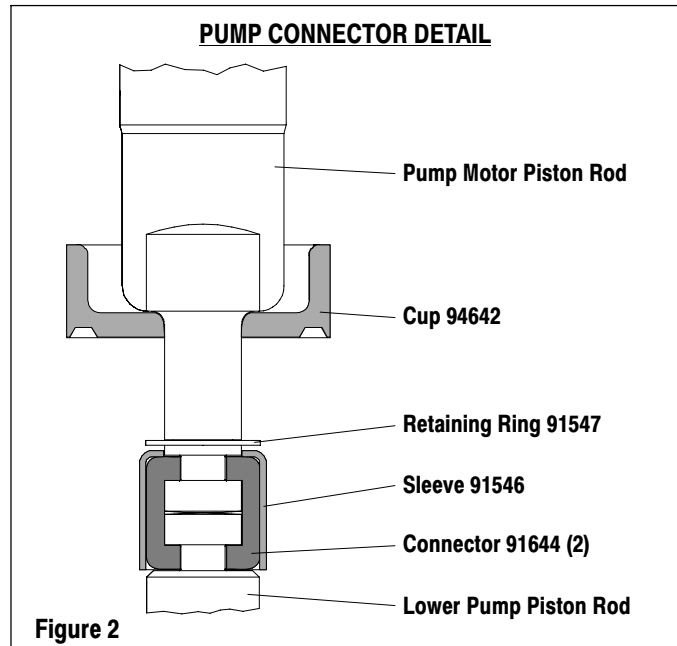

REASSEMBLY

1. Align the pump motor with the lower pump end.
2. Install the two connectors and retain with the sleeve, slide the retaining ring back into position.
3. Reinstall the spacer rods to the pump motor.
4. Bring the motor and lower pump together and retain with the three screws and washers.