

OPERATOR'S MANUAL

650939-X-B

INCLUDING: SPECIFICATIONS, SERVICE KITS, GENERAL INFORMATION, TROUBLESHOOTING.

INCLUDE MANUALS: 66475-X Lower Pump End (pn 97999-111), 67314-B Hydraulic Motor (pn 97999-1220) & S-632 General Information Manual (pn 97999-624)

RELEASED: 1-14-00

REVISED: 11-13-06
(REV. D)

4.125 SQ." HYDRAULIC MOTOR
2.4:1 RATIO
6" STROKE

650939-X4D-B
TWO BALL PUMP SERIES
 CARBON STEEL



**READ THIS MANUAL CAREFULLY BEFORE INSTALLING,
 OPERATING OR SERVICING THIS EQUIPMENT.**

It is the responsibility of the employer to place this information in the hands of the operator. Keep for future reference.

SERVICE KITS

- Use only genuine ARO® replacement parts to assure compatible pressure rating and longest service life.
- **637450** for repair of hydraulic motor section.
- **637098-X43** for repair of lower pump section. Refer to the chart on page 2 for description of -X4D options.

SPECIFICATIONS

Model Series (refer to option chart)	650939-X4D-B
Type	Hydraulic Operated, Two Ball Double Acting Pump
Ratio	2.4:1
Air Motor	67314-B
Motor Repair Kit	637450
Motor Size	4.125 sq." (26.6 sq. cm)
Stroke	6" (15.2 cm)
Hydraulic Inlet (female)	1/2 - 14 N.P.T.F. - 2
Hydraulic Return (female)	3/4 - 14 N.P.S.
Lower Pump End Series	66475-X4D
Lower Pump Repair Kit	637098-X43
Material Inlet (female)	2 - 11-1/2 N.P.T.F. - 1
Material Outlet (female)	1 - 11-1/2 N.P.T.F. - 1
Weight	140 lbs (63.5 kgs)

PERFORMANCE

Hydraulic Inlet Pressure Range	50 - 2000 p.s.i. (3.4 - 137.9 bar)
Fluid Pressure Range	120 - 4800 p.s.i. (8.3 - 331.0 bar)
Maximum Rec'd Cycles / Minute	50
Displacement In³ Per Cycle	20.3
Volume / Cycle	11.3 oz. (333.0 ml)
Cycles Per Gallon	11.4
Flow @ 50 Cycles / Minute	4.4 g.p.m. (16.7 l.p.m.)

PUMP DATA

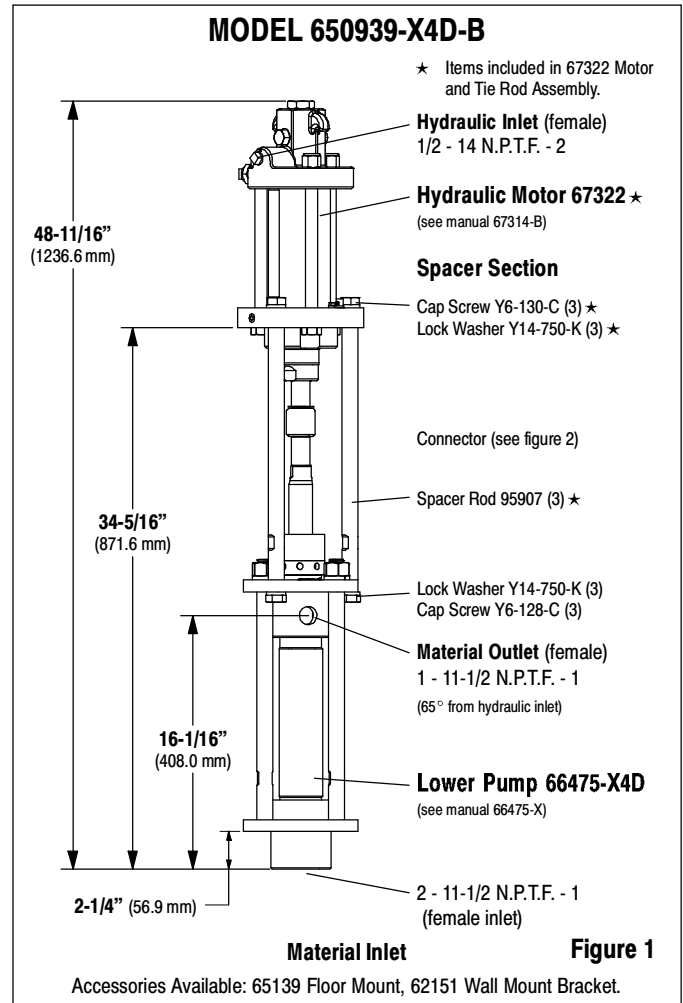

IMPORTANT

This is one of the four documents which support the pump. Replacement copies of these forms are available upon request.

- 650939-X-B Model Operator's Manual (pn 97999-881)
- S-632 General Information - Industrial Piston Pumps (pn 97999-624)
- 66475-X Lower Pump End Operator's Manual (pn 97999-111)
- 67314-B Hydraulic Motor Operator's Manual (pn 97999-1220)