

OPERATOR'S MANUAL

650939-X-B

INCLUDING: SPECIFICATIONS, SERVICE KITS, GENERAL INFORMATION, TROUBLESHOOTING.
 INCLUDE MANUALS: 66475-X Lower Pump End (pn 97999-111), 67314-B Hydraulic Motor (pn 97999-1220) &
 S-632 General Information Manual (pn 97999-624)

RELEASED: 1-14-00
 REVISED: 11-13-06
 (REV. D)

4.125 SQ." HYDRAULIC MOTOR
2.4:1 RATIO
6" STROKE

650939-X4D-B
TWO BALL PUMP SERIES
 CARBON STEEL



**READ THIS MANUAL CAREFULLY BEFORE INSTALLING,
 OPERATING OR SERVICING THIS EQUIPMENT.**

It is the responsibility of the employer to place this information in the hands of the operator. Keep for future reference.

SERVICE KITS

- Use only genuine ARO® replacement parts to assure compatible pressure rating and longest service life.
- **637450** for repair of hydraulic motor section.
- **637098-X43** for repair of lower pump section. Refer to the chart on page 2 for description of -X4D options.

SPECIFICATIONS

Model Series (refer to option chart)	650939-X4D-B
Type	Hydraulic Operated, Two Ball Double Acting Pump
Ratio	2.4:1
Air Motor	67314-B
Motor Repair Kit	637450
Motor Size	4.125 sq." (26.6 sq. cm)
Stroke	6" (15.2 cm)
Hydraulic Inlet (female)	1/2 - 14 N.P.T.F. - 2
Hydraulic Return (female)	3/4 - 14 N.P.S.
Lower Pump End Series	66475-X4D
Lower Pump Repair Kit	637098-X43
Material Inlet (female)	2 - 11-1/2 N.P.T.F. - 1
Material Outlet (female)	1 - 11-1/2 N.P.T.F. - 1
Weight	140 lbs (63.5 kgs)

PERFORMANCE

Hydraulic Inlet Pressure Range	50 - 2000 p.s.i. (3.4 - 137.9 bar)
Fluid Pressure Range	120 - 4800 p.s.i. (8.3 - 331.0 bar)
Maximum Rec'd Cycles / Minute	50
Displacement In³ Per Cycle	20.3
Volume / Cycle	11.3 oz. (333.0 ml)
Cycles Per Gallon	11.4
Flow @ 50 Cycles / Minute	4.4 g.p.m. (16.7 l.p.m.)

PUMP DATA

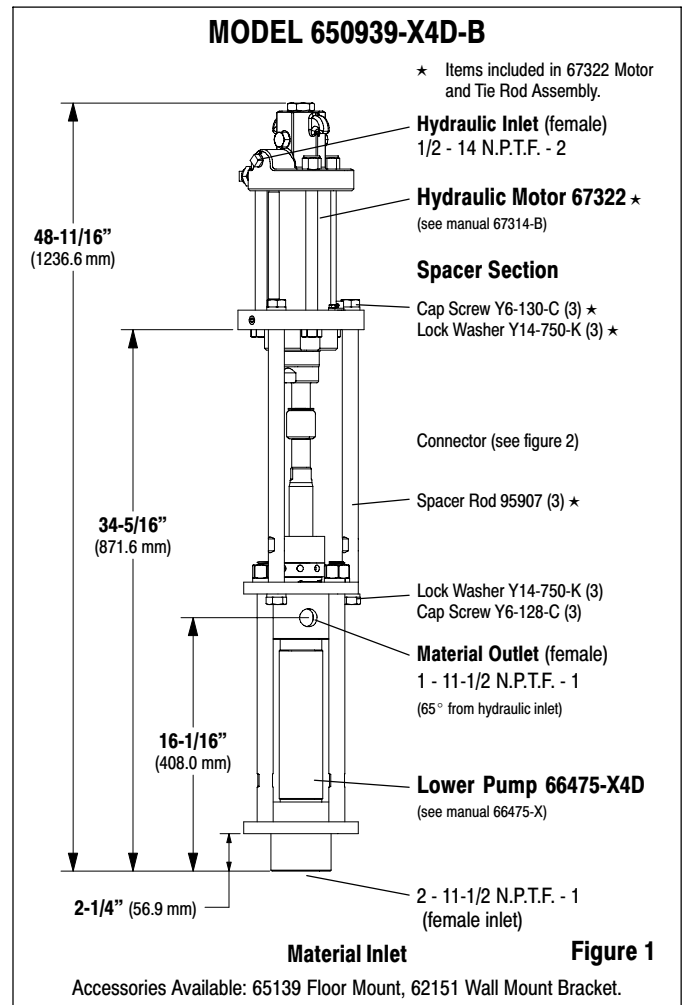

IMPORTANT

This is one of the four documents which support the pump. Replacement copies of these forms are available upon request.

- 650939-X-B Model Operator's Manual (pn 97999-881)
- S-632 General Information - Industrial Piston Pumps (pn 97999-624)
- 66475-X Lower Pump End Operator's Manual (pn 97999-111)
- 67314-B Hydraulic Motor Operator's Manual (pn 97999-1220)

PUMP OPTION DESCRIPTION CHART

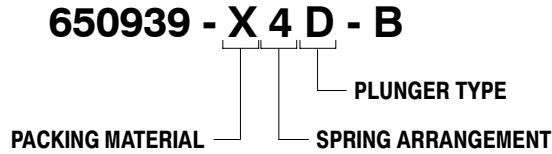

- PACKING MATERIAL** (packings are upper and lower unless noted)
- 3 Glass filled Teflon
 - C UHMW-PE
 - G UHMW-PE / Leather staggered
 - P UHMW-PE / Teflon staggered (upper) / UHMW-PE (lower)
 - R Teflon / UHMW-PE staggered (upper) / Glass filled Teflon (lower)

- SPRING ARRANGEMENT**
- 4 Multiple wave spring

- PLUNGER TYPE**
- D Hardened stainless steel with hard chrome plating

GENERAL DESCRIPTION

⚠ WARNING HAZARDOUS PRESSURE. Do not exceed maximum operating pressure of 4800 p.s.i. (331.0 bar) at 2000 p.s.i. (137.9 bar) inlet hydraulic pressure.

<p>PUMP RATIO X INLET PRESSURE TO PUMP MOTOR = MAXIMUM PUMP FLUID PRESSURE</p> <p>Pump ratio is an expression of the relationship between the pump motor area and the lower pump end area. EXAMPLE: When 90 p.s.i. (6.2 bar) inlet pressure is supplied to the motor of a 5:1 ratio pump it will develop a maximum of 450 p.s.i. (31.0 bar) fluid pressure (at no flow) – as the fluid control is opened, the flow rate will increase as the motor cycle rate increases to keep up with the demand.</p>
--

⚠ WARNING Refer to general information sheet for additional safety precautions and important information.

- The two-ball pumps are primarily designed for the high volume transfer of light and medium viscosity fluids compatible with carbon steel. The lower pump is designed for easy priming and the double acting feature is standard in all ARO industrial pumps. Material is delivered to the pump discharge outlet on both the up and down stroke.
- The motor is connected to the lower pump end by a spacer section. This allows for lubrication of the upper packing gland and prevents motor contamination because of normal wear and eventual leakage through the material packing gland. Be sure the solvent cup is adequately filled with lubricant to protect the upper packings and insure longest service life.

TROUBLE SHOOTING

Pump problems can occur in either the hydraulic motor section or the lower pump end section. Use these basic guidelines to help determine which section is affected.

If the pump will not cycle.

- Be certain to first check for non-pump problems including kinked, restrictive or plugged inlet / outlet hose or dispensing device. Depressurize the pump system and clean out any obstructions in the inlet / outlet material lines.
- Refer to the motor manual for trouble shooting if the pump does not cycle and / or hydraulic fluid leaks from the hydraulic motor.

If the pump cycles but does not deliver material.

- Refer to the lower pump end manual for further trouble shooting.

PUMP CONNECTION – UPPER / LOWER

NOTE: All threads are right hand.

1. Lay the pump assembly on a workbench.
2. Remove the top three (Y6-130-C) cap screws and (Y14-750-K) lockwashers from the three spacer rods (figure 1).
3. Pull the hydraulic motor from the lower pump end until motor piston rod is in the “down” position and lower pump end rod is in “up” position.
4. Using e-ring pliers, slide the “e” ring up far enough to allow the sleeve to move upward and release the two connectors (figure 2).

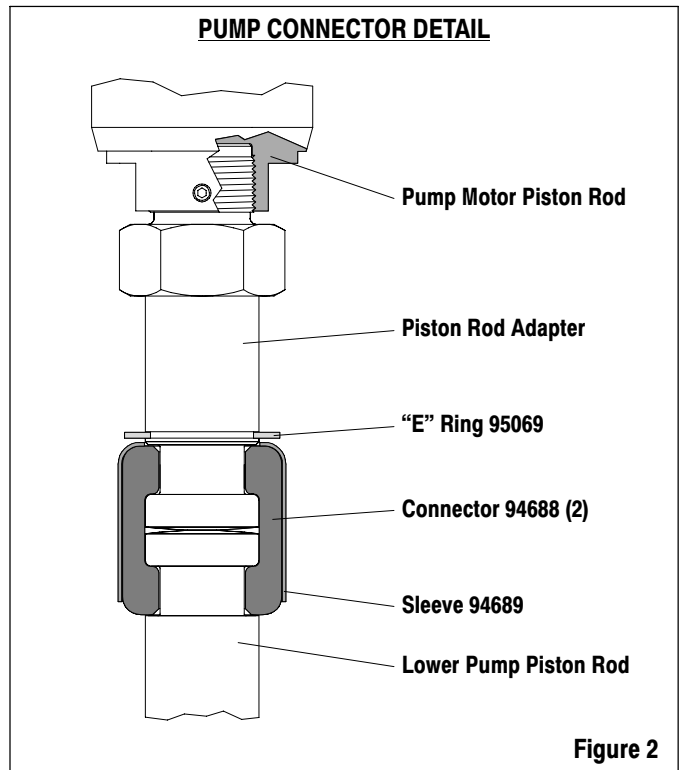

REASSEMBLY

1. Align the pump motor with the lower pump end. Position the hydraulic inlet 65° from the material outlet.
2. Install the two connectors and retain with the sleeve, slide the “e” ring back into position.
3. Reinstall the spacer rods to the pump motor.
4. Bring the motor and lower pump together and retain with the three (Y14-750-K) lockwashers and (Y6-130-C) cap screws.