

OPERATOR'S MANUAL

650919

INCLUDING: OPERATION, INSTALLATION & MAINTENANCE

INCLUDE MANUALS: 66475-X LOWER PUMP END (PN 97999-111), 66554-X CART (PN 97999-574), 650963-X-B PUMP (97999-880), 651418-X-B FILTER (97999-8), 651728 MANIFOLD (PN 97999-419) & GENERAL INFORMATION S-632 (97999-624)

RELEASED: 7-2-82

REVISED: 11-17-00

(REV. D)

650919

CART AND PUMP ASSEMBLY

12" CARBON STEEL, TWO BALL PUMP, 65:1 RATIO

**READ THIS MANUAL CAREFULLY BEFORE INSTALLING, OPERATING OR SERVICING THIS EQUIPMENT.**

It is the responsibility of the employer to place this information in the hands of the operator. Keep for future reference.

SERVICE KITS

- Use only genuine ARO® replacement parts to assure compatible pressure rating and longest service life.
- **637112 for repair of Air Motor section.**
Service Note: The Air Motor Service / Parts Manual is not shipped with the pump but it is included with each Service Kit. If this Service / Parts Information is needed, request the Air Motor Operator's Manual from ARO. (Manual 66506-B, PN 97999-870).
- **637098-G43 for repair of Lower Pump section.**

PUMP SYSTEM DATA

Model	650919
Pump System Type	Cart Mounted Portable, Air Operated, Two Ball
Pump Model	650963-G4D-B
Ratio	65:1
Air Inlet	3/4" - 14 N.P.T.F.-1 (female)
Air Exhaust	Muffler included
Material Inlet	2" - 11-1/2 N.P.T.F.-1 (female)
Dimensional Data	See page 4.
Air Motor	66506-B
Motor Repair Kit	637112
Lower Pump End	66475-G4D
Lower Pump Repair Kit	637098-G43

PERFORMANCE

Air Inlet Pressure Range	30 - 90 p.s.i. (2.1 - 6.2 bar)
Fluid Pressure Range	1950 - 5850 p.s.i. (134.5 - 403.4 bar)
Max. Rec'd Cycles / Minute	70
Displacement In ³ Per Cycle	20.7
Volume / Cycle	11.5 oz. (339.1 ml)
Cycles Per Gallon	11.2
Flow @ 70 Cycles / Minute	6.27 g.p.m. (23.7 l.p.m.)
Noise Level @ 60 psi - 40 cpm	89.8 db(A) *

* The pump sound pressure level has been updated to an Equivalent Continuous Sound Level (L_{Aeq}) to meet the intent of ANSI S1. 13-1971, CAGI-PNEUROP S5.1 using four microphone locations.

⚠ WARNING HIGH PRESSURE DEVICE. Improper usage of equipment could result in serious injury. The possibility of injection into the flesh is a potential hazard. Never allow any part of the human body to come in front of or in direct contact with the material outlet. An injection can be serious! If injection should occur, contact a qualified physician for immediate treatment of such injuries.

⚠ WARNING Do not exceed maximum working pressure of 5850 p.s.i. (6.2 bar) air inlet pressure.

**IMPORTANT** This is one of the seven documents which support the system. Replacement copies of these forms are available upon request.

- 66475-X LOWER PUMP END OPERATOR'S MANUAL (97999-111)
- 66554-X CART ASSEMBLY OPERATOR'S MANUAL (97999-574)
- 650919 PUMP SYSTEM OPERATOR'S MANUAL (97999-514)
- 650963-X-B PUMP MODEL OPERATOR'S MANUAL (97999-880)
- 651418-X-B MATERIAL FILTER OPERATOR'S MANUAL (97999-8)
- 651728 MANIFOLD ASSEMBLY OPERATOR'S MANUAL (97999-419)
- GENERAL INFORMATION MANUAL S-632 (97999-624)



GENERAL DESCRIPTION

The Aro Model 650919 Pump and Cart Assembly is designed to provide portability to a pump that is primarily used for airless spraying applications.

Materials of light to medium viscosity are suited for the unit.

INSTALLATION

The unit comes completely assembled.

Spray gun and hoses are not included with this unit.

These items must be capable of withstanding 5850 p.s.i. (403 bar) working pressure.

Connect hose (furnished by customer) to 66593 ball valve. This unit can accommodate 3 guns and hoses.

OPERATION

See 650963-X-B pump manual installation for flushing instructions.

Be sure material hoses and other components are able to withstand fluid pressures developed by this pump.

After the pump has been flushed with a compatible solvent and is ready to operate.

1. Place 66728 suction hose assembly into material.

2. Connect air line to 651728 Filter - Regulator - Lubricator.
3. Turn knob, on air regulator, clockwise, to start pump.
4. Allow pump to cycle slowly and prime with material. This will bleed trapped air from the system.

MAINTENANCE

The air line lubricator should be filled at all times.

The air line should be disconnected from the air motor if the pump sits idle for long periods of time.

Periodically check the screen (93945-70 70 mesh) located in the 651418-70-B material filter and pulsation dampener assembly.

TROUBLE SHOOTING

No material (stalled pump).

- Obstructed spray tip. Remove spray tip and clean.
- Obstructed hose assembly. Remove control handle and operate until line is clear.
- Obstructed control handle assembly. Disassemble control handle and clean.

No material (pump continually cycles).

- Empty material supply. Disconnect air. Replace material supply. Reconnect air. Prime pump.

For other trouble shooting tips, refer to 650963-X-B Operator's Manual.

PARTS LIST / 650919

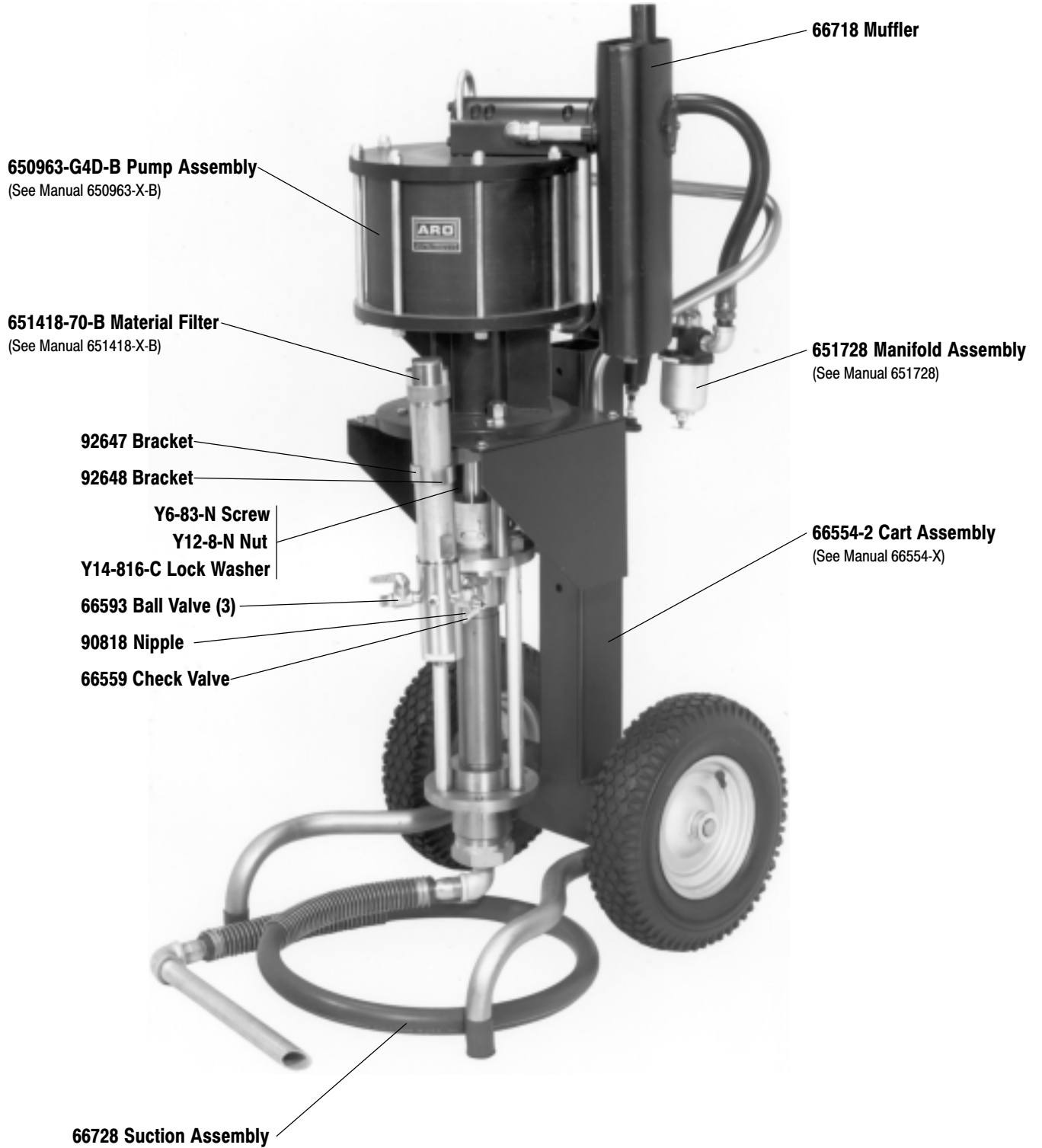

DIMENSIONAL DATA

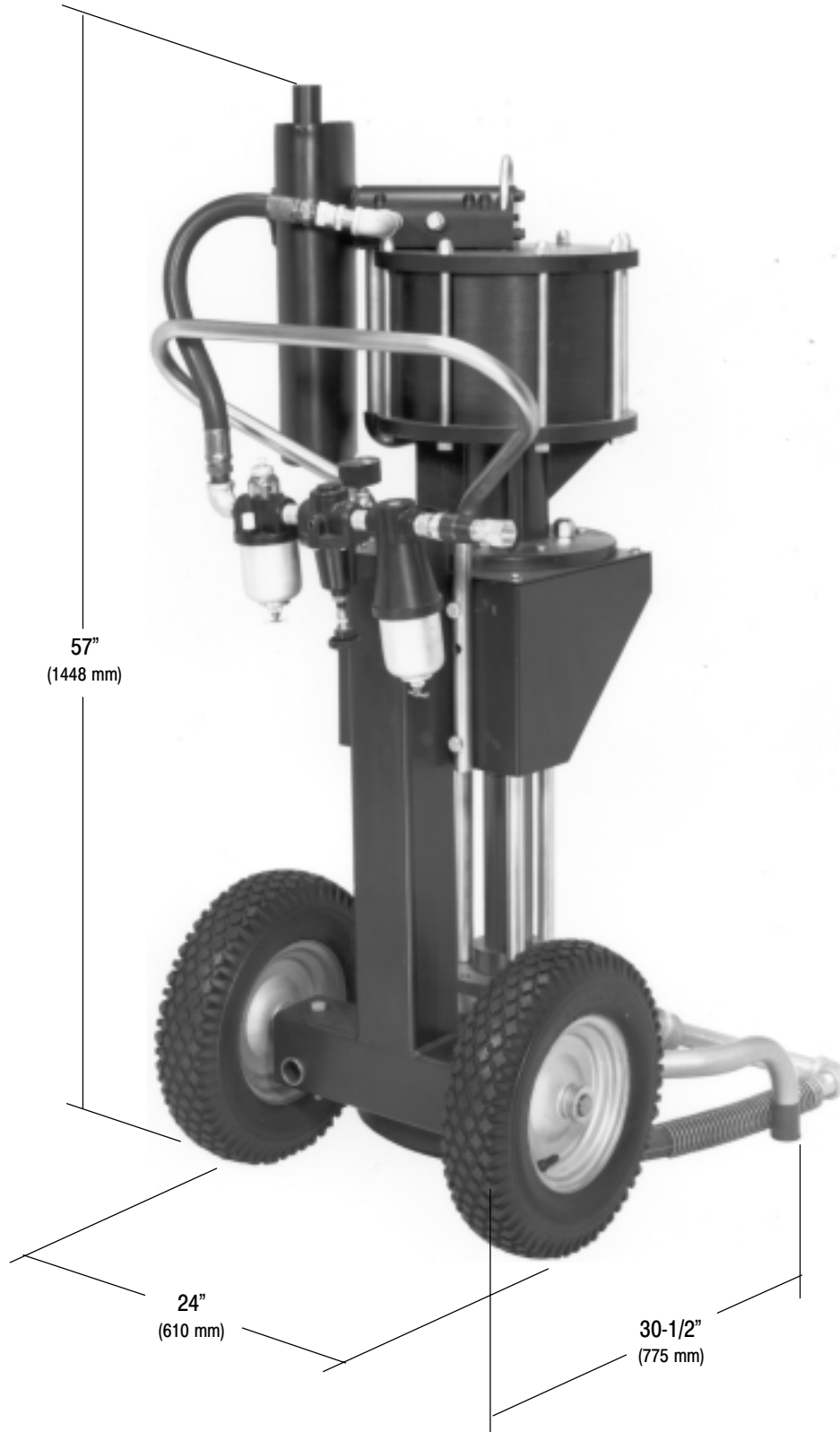

Approximate overall dimensions