

PARTS LIST / 650719-C FLUID SECTION

❶ 637138-63 fluid section service kits include: Balls (item 22), diaphragms (item 7) plus items 2, 3, 19 and 93706-1 Key-Lube grease (page 6).

PARTS LIST

Item	Description (size)	Qty	Part No.	[Mtl]	Item	Description (size)	Qty	Part No.	[Mtl]
❶ 1	Rod	(1)	98720-1	[C]	❶ 19	"O" Ring (1/8" x 2-3/4" o.d.)	(4)	Y327-230	[V]
❶ 2	"O" Ring (3/32" x 1" o.d.)	(1)	Y330-117	[B]	21	Seat	(4)	92942	[K]
❶ 3	"O" Ring (1/16" x 3/4" o.d.)	(4)	Y327-16	[V]	❶ 22	Ball (1-3/4" diameter)	(4)	92757-6	[D]
5	Plate - air side	(2)	92752	[C]	26	Bolt (3/8" - 16 x 1-1/4")	(8)	Y6-66-C	[C]
❶ 6	Plate - fluid side	(2)	92752	[C]	27	Bolt (5/16" - 18 x 2-1/4")	(4)	Y6-510-C	[C]
❶ 7	Diaphragm	(2)	92755-3	[V]	29	Nut (5/16" - 18)	(20)	Y12-5-C	[C]
9	Washer (0.630" i.d.)	(2)	93065	[SS]	32	Leg	(2)	92759	[C]
14	Screw (5/8" - 18 x 1-1/2")	(2)	Y5-107-T	[SS]	43	Ground Lug (see page 7)	(1)	93004	[Co]
15	Fluid Cap	(2)	92750	[A]	59	Bolt (5/16" - 18 x 2")	(16)	93608	[C]
16	Manifold (top with valve port)	(1)	93129	[A]	81	Relief Valve	(1)	96333	[Br]
	Manifold (bottom)	(1)	92855	[A]					

Service Note: Part number 98931-T installation tool is available separately for use with items (1) and (2).

❶ "Smart Parts", keep these items on hand in addition to the service kit for fast repair and reduction of down time.

❶ Service Kit Note: Extra "O" rings are included in kits to service models built prior to December 1989.

MATERIAL CODE

- [A] = Aluminum
- [B] = Nitrile
- [Br] = Brass
- [C] = Carbon Steel
- [Co] = Copper
- [D] = Acetal
- [K] = Kynar PVDF
- [SS] = Stainless Steel
- [V] = Viton

FLUID SECTION DISASSEMBLY

1. Remove top manifold(s).
2. Remove (22) balls, (19) "O" rings and (21) seats.
3. Remove (15) fluid caps.
4. Remove (14) screw, (9) washer, (3) "O" ring, (6) plate, (7) diaphragm and (5) plate.
5. Remove (3) "O" rings.

NOTE: Do not scratch or mar the surface of (1) diaphragm rod.

FLUID SECTION REASSEMBLY

- Reassemble in reverse order.
- Clean and inspect all parts. Replace worn or damaged parts with new parts as required.
- Lubricate (1) diaphragm rod and (2) "O" ring with Key-Lube "O" ring lube or equivalent.
- Use ARO pn 98931-T bullet (installation tool) to aid in installation of (2) "O" ring on (1) diaphragm rod.
- Be certain (7) diaphragms align properly with (15) fluid caps before making final torque adjustments on bolt and nuts to avoid twisting the diaphragm.
- Re-check torque settings after pump has been re-started and run a while.

PARTS LIST / 650719-C FLUID SECTION

FOR THE AIR MOTOR SECTION, SEE PAGES 6 & 7.

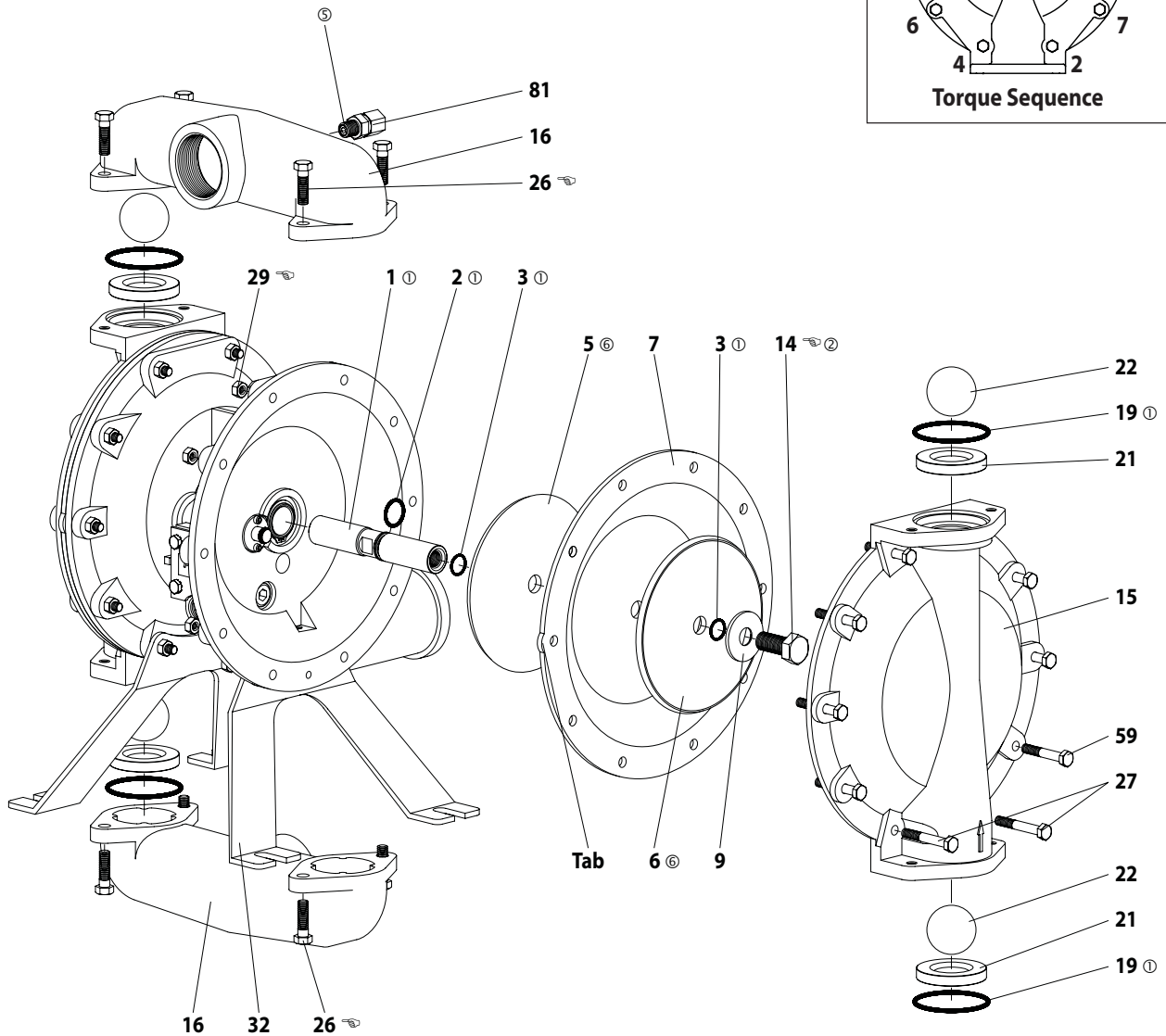
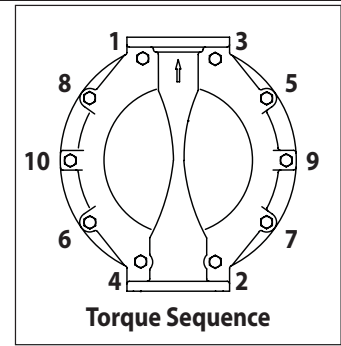
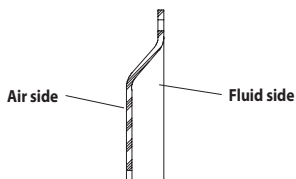

Figure 2



Cross section view of diaphragm.

ASSEMBLY TORQUE REQUIREMENTS

NOTE: DO NOT OVERTIGHTEN FASTENERS.

- (14) Diaphragm screw, 65 - 70 ft. lbs (88.1 - 94.9 Nm).
- (26) Bolt, 240 - 280 in. lbs (27.1 - 31.6 Nm).
- (29) Nut, 120 - 140 in. lbs (13.6 - 15.8 Nm).

LUBRICATION / SEALANTS

- ① Apply Key-Lube grease (93706-1) to all "O" rings, "U" cups and mating parts.
- ② Apply Loctite® 271™ to threads.
- ⑤ Apply gasolene-resistant pipe sealant to pipe threads.
- ⑥ NOTICE: Radius edge of parts (5 and 6) is against diaphragm.

PARTS LIST / 650719-C AIR MOTOR SECTION

④ Indicates parts included in 637118-C air section repair kit.

AIR MOTOR PARTS LIST

Item	Description (size)	(Qty)	Part No.	[Mtl]
101	Motor Body (includes items 195)	(1)	93161	[A]
② 102	"O" Ring (0.07" x 1.25" o.d.)	(2)	92960	[B]
② 103	Sleeve	(1)	94528	[D]
④ 104	Retaining Ring (1-5/32 i.d.)	(2)	Y145-26	[C]
105	Screw / Washer (1/4" - 20 x 5/8")	(8)	93860	[C]
107	Plate	(2)	93707-1	[SS]
④ 108	Gasket (with notch)	(1)	92878	[B/Ny]
② 109	Piston	(1)	92011	[D]
④ 110	"U" Cup (3/16" x 1-3/8" o.d.)	(1)	Y186-51	[B]
② 111	Spool	(1)	92005	[A]
112	Washer (1.556" o.d.)	(5)	92877	[Z]
④ 113	"O" Ring (1/8" x 1-1/4" o.d.)	(5)	Y325-214	[B]
④ 114	"O" Ring (3/32" x 1-9/16" o.d.)	(6)	Y325-126	[B]
② 115	Spacer	(4)	92876	[Z]
② 116	Spacer	(1)	92006	[Z]
④ 117	Gasket	(1)	92004	[B/Ny]

Item	Description (size)	(Qty)	Part No.	[Mtl]
118	Pilot Rod	(1)	93309-2	[C]
④ 119	"O" Ring (1/8" x 3/4" o.d.)	(4)	93075	[U]
120	Spacer	(3)	115959	[Z]
121	Sleeve Bushing	(2)	98723-2	[Bz]
④ 122	"O" Ring (3/32" x 9/16" o.d.)	(2)	94820	[U]
④ 123	Screw (#8 - 32 x 3/8")	(4)	Y154-41	[C]
126	Pipe Plug (1/2 - 14 N.P.T. x 17/32")	(1)	Y227-5-L	[C]
127	90° Street Elbow (3/4 - 14 N.P.T.)	(1)	Y43-5-C	[C]
128	Pipe Plug (1/8 - 27 N.P.T. x 1/4")	(1)	Y227-2-L	[C]
195	Button Head Screw (1/4" - 20 x 1/4")	(2)	94987	[SS]
196	Button Head Screw (1/4" - 20 x 3/8")	(1)	94987-1	[SS]
201	Muffler	(1)	350-568	[C]
④	Key-Lube "O" Ring Lubricant	(1)	93706-1	
	Key-Lube, 10 Pack		637175	

② "Smart Parts", keep these items on hand in addition to the service kit for fast repair and reduction of down time.

MATERIAL CODE

[A] = Aluminum	[C] = Carbon Steel	[SS] = Stainless Steel
[B] = Nitrile	[D] = Acetal	[U] = Polyurethane
[Bz] = Bronze	[Ny] = Nylon	[Z] = Zinc

AIR MOTOR SECTION SERVICE

Service is divided into two parts - 1. Pilot Valve, 2. Major Valve.

GENERAL REASSEMBLY NOTES:

- Air Motor Section service is continued from Fluid Section repair.
- Inspect and replace old parts with new parts as necessary. Look for deep scratches on metallic surfaces, and nicks or cuts in "O" rings.
- Take precautions to prevent cutting "O" rings upon installation.
- Lubricate "O" rings with Key-Lube grease or equivalent.
- Do not over-tighten fasteners. Refer to torque specification block on view.
- Re-torque fasteners following restart.

PILOT VALVE DISASSEMBLY

1. Remove (104) retaining ring.
2. Remove (123) screws and (122) "O" rings.
3. Remove (118) pilot rod, (121) sleeve bushing, (119) "O" rings and (120) spacers from the (101) motor body.
4. Remove (103) sleeve and (102) "O" rings.

PILOT VALVE REASSEMBLY

1. Replace two (102) "O" rings, if worn or damaged, and reinstall (103) sleeve.
2. Install one of the (121) sleeve bushings, (119) "O" rings, (120) spacers and the remaining (121) bushing.
3. Carefully push (118) pilot rod into bushing etc. and retain on each end with the two (122) "O" rings. Retain with (123) screws.
4. Replace (104) retaining rings.

MAJOR VALVE DISASSEMBLY

1. Remove (107) plate and (108 and 117) gaskets.
2. On the side opposite the air inlet, push on the inner diameter of (111) spool. This will force the (109) piston out. Continue pushing the (111) spool and remove. Check for scratches and gouges.
3. Reach into the air section (exhaust side) and remove (116) spacer, (115) spacers, (113) "O" rings, (114) "O" rings, (112) washers, etc. Check for damaged "O" rings.

MAJOR VALVE REASSEMBLY

NOTE: Replace worn parts as necessary. Lubricate "O" rings with Key-Lube or equivalent when reassembling.

1. Replace (112) washer, (114) "O" ring and (113) "O" ring onto (115) spacer and insert etc. **NOTE: Be careful to orient spacer legs away from blocking internal ports.**
2. Lubricate and carefully insert (111) spool.
3. Install (117) gasket and (107) plate.
4. Lubricate and install (110) packing cup and insert (109) piston into (air inlet side) cavity, the (110) packing cup lips should point outward.
5. Install (108) gasket and replace (107) plate.

PARTS LIST / 650719-C AIR MOTOR SECTION

IMPORTANT
BE CERTAIN TO ORIENT (115) SPACER LEGS
AWAY FROM BLOCKING INTERNAL PORTS
WHEN REASSEMBLING AIR SECTION.

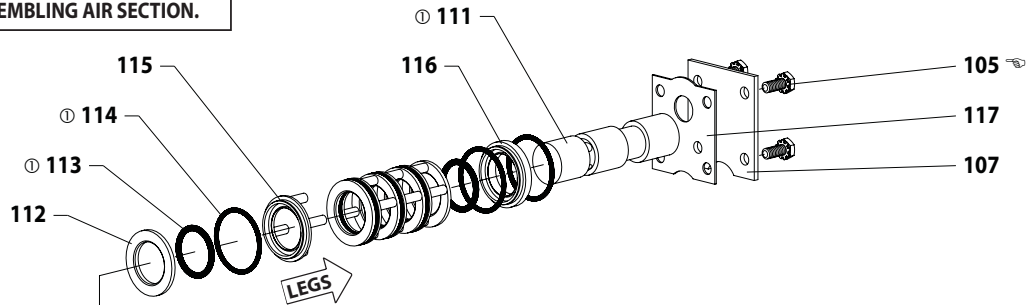

MAJOR VALVE
See cross section detail, figure 4.

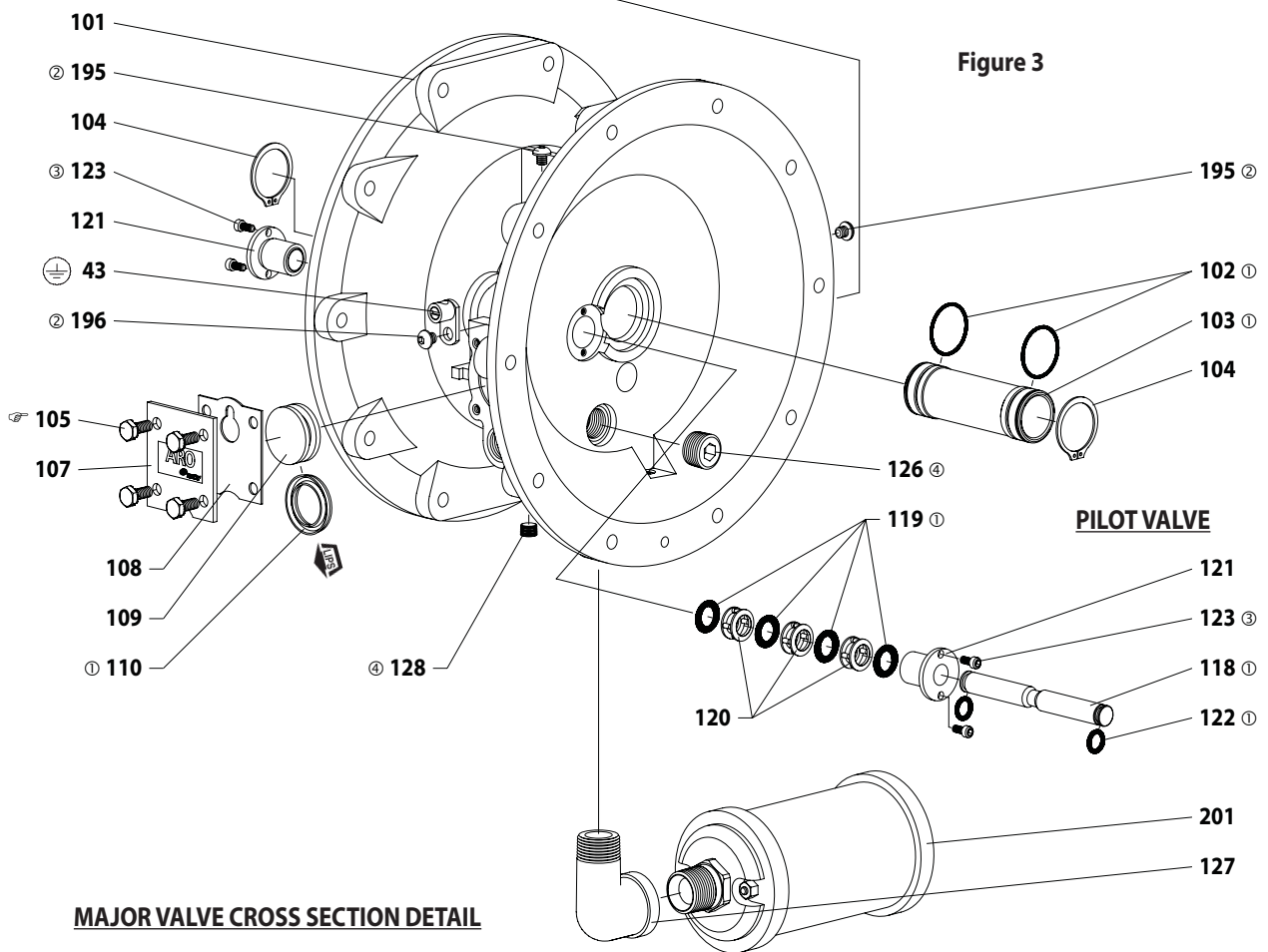

Figure 3

MAJOR VALVE CROSS SECTION DETAIL

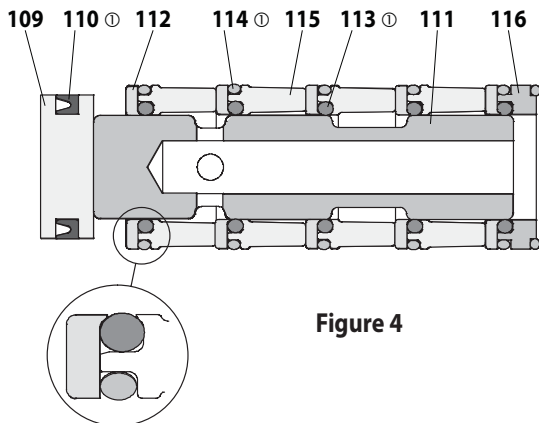

Figure 4

ASSEMBLY TORQUE REQUIREMENTS

NOTE: DO NOT OVERTIGHTEN FASTENERS.
(105) Screws, 40 - 50 in. lbs (4.5 - 5.6 Nm).

LUBRICATION / SEALANTS

- ① Apply Key-Lube grease to all "O" rings, "U" cups and mating parts.
- ② Apply Loctite 271 to threads.
- ③ Apply Loctite 262™ to threads.
- ④ Apply Loctite 572™ to threads.