

SALES & ENGINEERING DATA

RATIO SERIES: **46:1**

FLUID PSI RANGE: **0 - 7485**

650692-X43-B

EXTRUSION PUMP

RELEASED: 11-6-98
 REVISED: 5-27-10
 (REV. 02) S-1066

DIMENSIONAL DATA

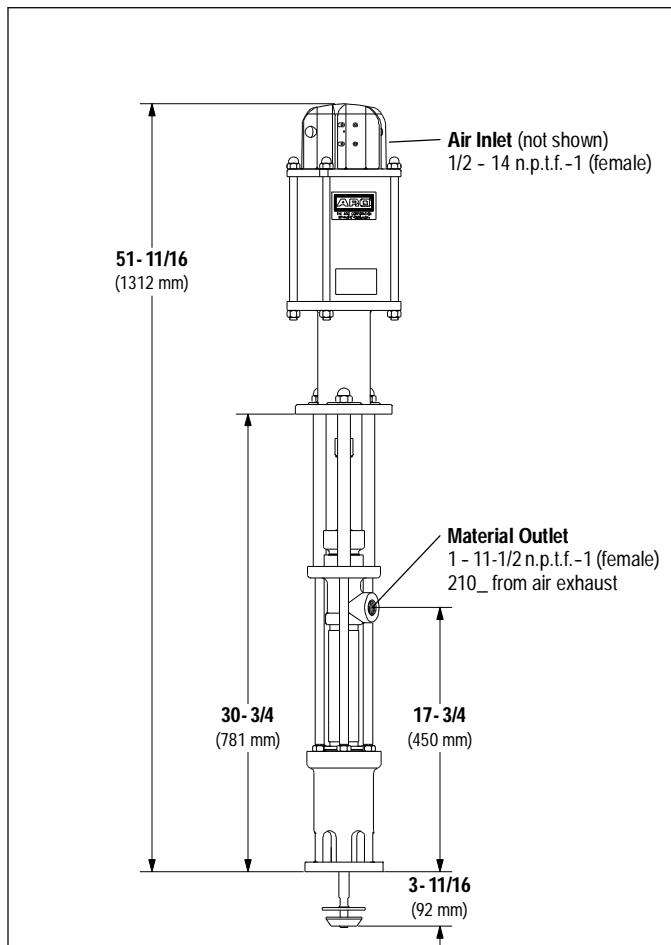

BOTTOM VIEW

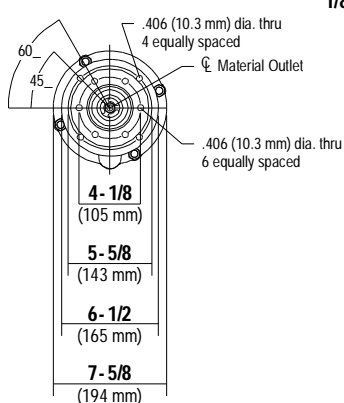

TOP VIEW

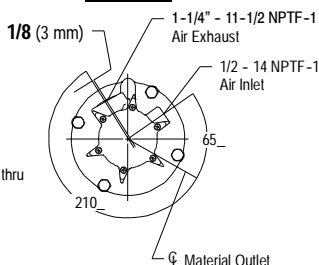

NOTE: Dimensions are shown in inches and (mm), supplied for reference only and are typically rounded up to the nearest 1/16 inch.

SPECIFICATIONS

CONSTRUCTION

- Model Series (refer to option chart) 650692-X43-B
- Pump Type Air Operated, Extrusion, Double Acting Pump
- Ratio 46:1
- Air Motor 65665-B
- Motor Repair Kit 61355
- Motor Diameter 6" (152.4 mm)
- Stroke 6" (152.4 mm)
- Air Inlet 1/2 - 14 n.p.t.f.-1 (female)
- Air Exhaust 1-1/4 - 11-1/2 n.p.t.f.-1 (female)
- Lower Pump End Series 66266-X43-B
- Lower Pump Repair Kit 637074-X43-B
- Packing Options:

- 3 - Glass Filled PTFE
- C - UHMW-PE
- G - UHMW-PE / Leather staggered
- P - UHMW-PE / PTFE staggered upper S UHMW-PE lower
- R - PTFE / UHMW-PE staggered upper S PTFE lower

- Material Inlet
- Material Outlet 1 - 11-1/2 n.p.t.f. - 1 (female)

MATERIALS OF CONSTRUCTION

- Outlet Body Ductile Iron, Nickel plated
- Cylinder Carbon Steel, E Nickel plated
- Plunger 17-4 Stainless Steel, Chrome plated
- Upper Check 440 Stainless Steel
- Upper Seat 440 Stainless Steel
- Lower Check 440 Stainless Steel
- Lower Seat 440 Stainless Steel
- Inlet Body Ductile Iron, Nickel plated
- Weight 67 lbs (30.4 kgs)

PERFORMANCE

- Air Inlet Pressure Range 0 - 150 p.s.i. (0 - 10.3 bar)
- Fluid Pressure Range 0 - 7485 p.s.i. (0 - 516.2 bar)
- Max. Rec'd Cycles / Minute 60
- Displacement In³ Per Cycle 6.97
- Volume / Cycle 3.9 oz. (114.2 ml)
- Cycles Per Gallon 33.1
- Flow @ 60 Cycles / Minute 1.8 g.p.m. (6.9 l.p.m.)
- Noise Level @ 60 p.s.i. - 40 c.p.m. 83.0 db(A)①

① Tested with 91790 Muffler installed. The pump sound pressure level has been updated to an Equivalent Continuous Sound Level (L_{Aeq}) to meet the intent of ANSI S1. 13-1971, CAGI-PNEUROP S5.1 using four microphone locations.

- ACCESSORIES:**
- 66101 Wall Mount Bracket
 - 67187-1 Mounting Post
 - 91790 Silencer



PERFORMANCE CURVES

