

SALES & ENGINEERING DATA

RATIO SERIES: **30:1**

FLUID P.S.I. RANGE: **900 - 4629**

650485-XXX TWO-BALL PUMP SERIES

RELEASED: 12-12-95
 REVISED: 5-27-10
 (REV. 02) S-835

DIMENSIONAL DATA

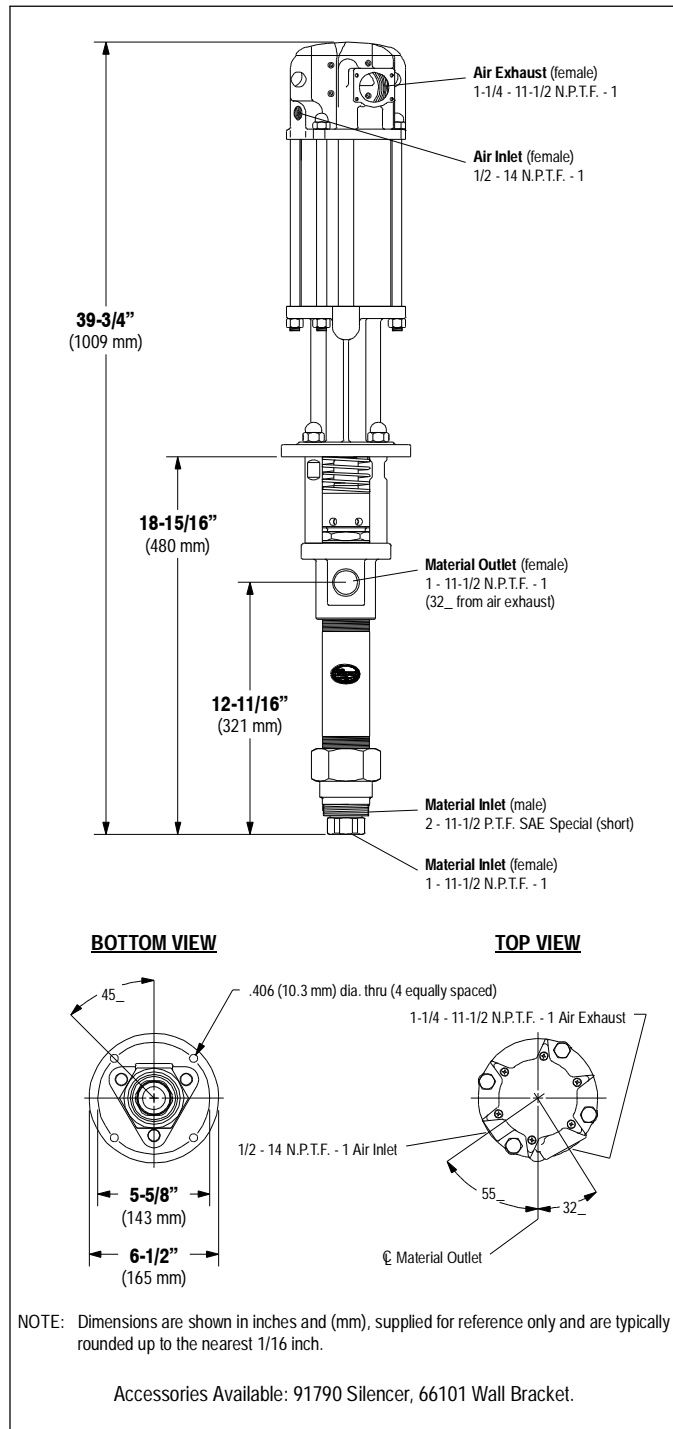

SPECIFICATIONS

CONSTRUCTION

Model Series (refer to option chart below)	650485-XXX
Pump Type	Air Operated, Two-Ball
Ratio	30:1
Air Motor	65465-B
Motor Repair Kit	61268
Motor Diameter	4-1/4" (10.8 cm)
Stroke	6"
Air Inlet (female)	1/2 - 14 N.P.T.F. - 1
Air Exhaust (female)	1-1/4 - 11-1/2 N.P.T.F. - 1
Lower Pump End Series	66302-XXX
Lower Pump Repair Kit	637307-X43
Packing Options:	

- 3 - Glass Filled PTFE (upper and lower)
- C - UHMW-PE (upper and lower)
- G - UHMW-PE / Leather staggered (upper and lower)
- P - UHMW-PE / Glass Filled PTFE staggered (upper)
UHMW-PE (lower)
- R - Glass Filled PTFE / UHMW-PE staggered (upper)
Glass Filled PTFE (lower)

Material Inlet (female)	1 - 11-1/2 N.P.T.F. - 1
(male)	2 - 11-1/2 P.T.F. SAE (short)
Material Outlet (female)	1 - 11-1/2 N.P.T.F. - 1

MATERIALS OF CONSTRUCTION

Lower Pump End Materials: ①	
Outlet Body	CF8M Stainless Steel
Cylinder (-XX3)	316 Stainless Steel Hard Chrome
(-XXB)	316 Stainless Steel Ceramic Coated
Plunger (-XX3)	17-4 Stainless Steel Hard Chrome
(-XXB)	17-4 Stainless Steel Ceramic Coated
Upper Ball	316 Stainless Steel
Upper Seat	Tungsten Carbide
Lower Ball	316 Stainless Steel
Lower Seat	Tungsten Carbide
Inlet Body	CF8M Stainless Steel
Weight	42.9 lbs (19.5 kgs)

PERFORMANCE

Air Inlet Pressure Range	30 - 150 p.s.i. (2 - 10.3 bar)
Fluid Pressure Range	900 - 4629 p.s.i. (62 - 319 bar)
Maximum Rec'd Cycles / Minute	60
Displacement In³ Per Cycle	5.5
Volume / Cycle	3 oz. (90.3 ml)
Cycles Per Gallon	41.9
Flow @ 60 Cycles / Minute	1.3 g.p.m. (4.9 l.p.m.)
Noise Level @ 60 p.s.i. - 40 c.p.m. ②	81.8 db(A)

① All wetted components are passivated or electro-polished and have corrosion resistance characteristics of 300 Series stainless steel.

② Tested with 91790 silencer installed. The pump sound pressure level has been updated to an Equivalent Continuous Sound Level (L_{Aeq}) to meet the intent of ANSI S1.13-1971, CAGI-PNEUROP S5.1 using four microphone locations.

PERFORMANCE CURVES

TWO-BALL PUMP, 4-1/4" AIR MOTOR, 6" STROKE, 30:1 RATIO

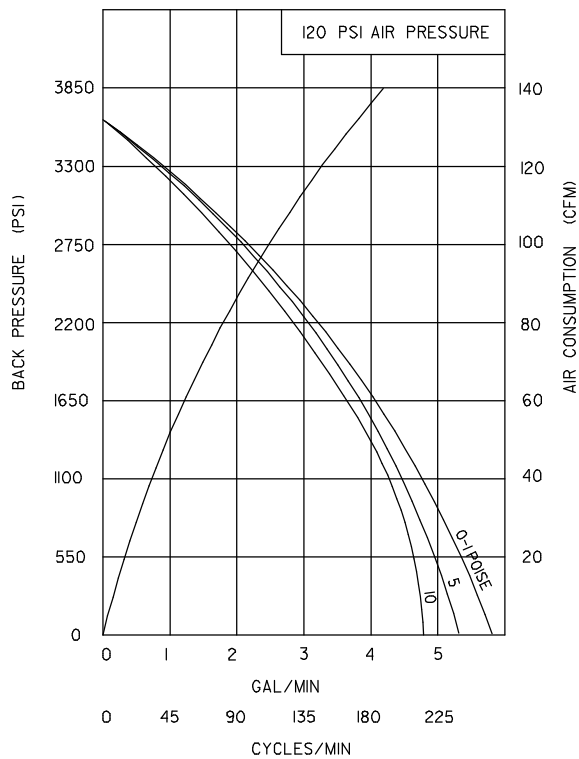
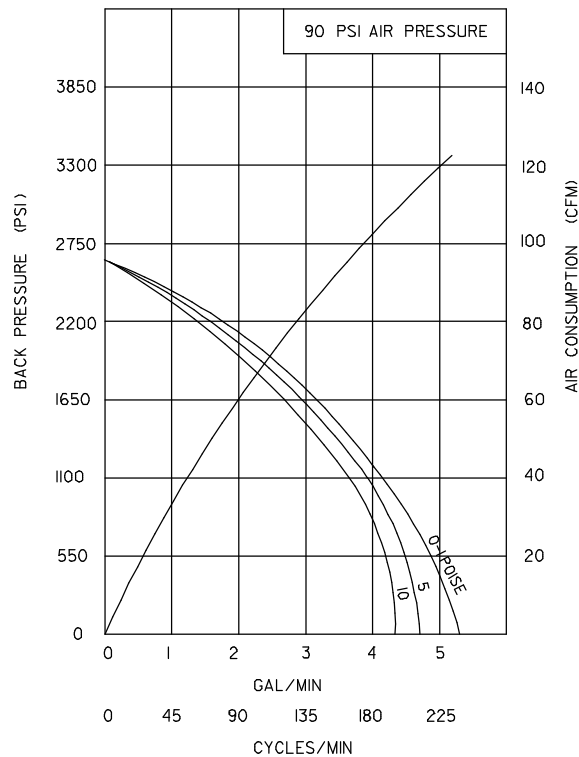
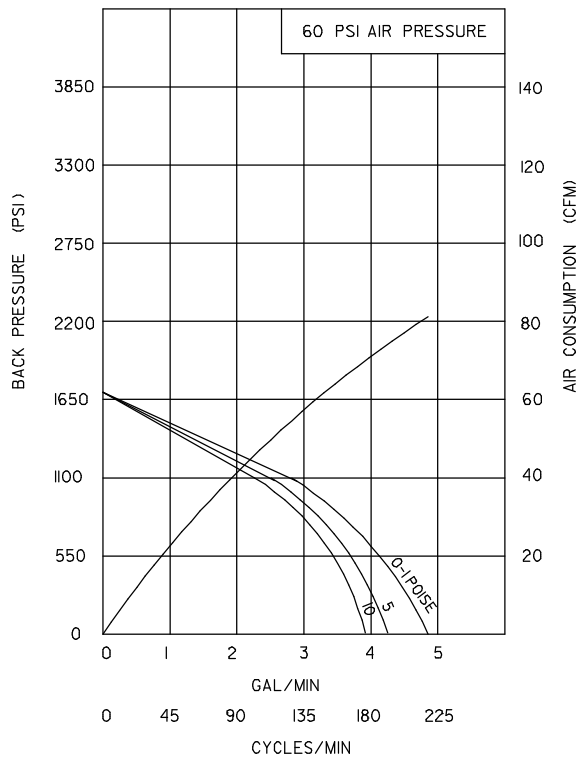

650485-XXX SERIES