

OPERATOR'S MANUAL

650453-X

INCLUDING: OPERATION, INSTALLATION & MAINTENANCE

ALSO INCLUDE MANUALS: 6544X-X (PN 97999-64) AIR MOTOR & S-632 GENERAL INFORMATION MANUAL (PN 97999-624)

RELEASED: 10-24-92

REVISED: 1-6-03

(REV. G)

4-1/4" AIR MOTOR
9:1 RATIO
4" STROKE

650453-X
2-BALL BASIC PUMP



READ THIS MANUAL CAREFULLY BEFORE INSTALLING, OPERATING OR SERVICING THIS EQUIPMENT.

It is the responsibility of the employer to place this information in the hands of the operator. Keep for future reference.

SERVICE KITS

- Use only genuine ARO® replacement parts to assure compatible pressure rating and longest service life.
- 61268 for repair of air motor section.
- 637177 for repair of lower pump end of models 650453-5 and 650453-11.
- Order lower pump end service parts separately for models 650453-7, 650453-8, 650453-9 and 650453-10.

GENERAL DESCRIPTION

- The ARO 9:1 ratio basic pump assembly consists of a 4-1/4" air motor, spacer section and two-ball lower pump end. The 4-1/4" air motor is a reciprocating type with pneumatic control circuit and reversing valve. No working springs or piston connected trip rods are used to reverse the air motor piston.

SPACER SECTION

- The air motor is connected to the lower pump end with a spacer tube and solvent cup. This allows for lubrication of the upper packing gland and to prevent air motor contamination because of normal wear and eventual leakage through the material packing gland.

LOWER PUMP END

- The two-ball design provides for easy priming of the lower foot valve and the double acting feature is standard in all ARO industrial pumps. Material is delivered to the pump discharge outlet on both the up and down stroke.

RATIO X REGULATED AIR PRESSURE TO AIR MOTOR = MAXIMUM FLUID PRESSURE.

- The 9:1 ratio is an expression of the relationship between the air motor area and the lower pump end area. When 150 p.s.i. (10.3 bar) air pressure is supplied to the air motor, the lower pump end will develop a maximum of 1,350 p.s.i. (93.1 bar) fluid pressure (at no flow). As the fluid control is opened, the flow rate will increase as the air motor cycle rate increases to keep up with the demand.

OPERATING PRECAUTIONS

- DO NOT exceed maximum working pressure of 1,350 p.s.i. (93.1 bar) at 150 p.s.i. (10.3 bar) air inlet pressure. **HEED ALL WARNINGS.**
- **WARNING: HIGH PRESSURE DEVICE.** Improper usage of this equipment could result in serious injury. The possibility of injection into the flesh is a potential hazard. Never allow any part of the human body to come in front of or in direct contact with the material outlet. An injection injury can be serious. If injection should occur, contact a qualified physician immediately for treatment.
- **COMPONENT RUPTURE.** This pump is capable of producing high material pressure as stated on pump model plate.
- Be sure material hoses and other components are able to withstand fluid pressures developed by this pump.

PUMP DATA

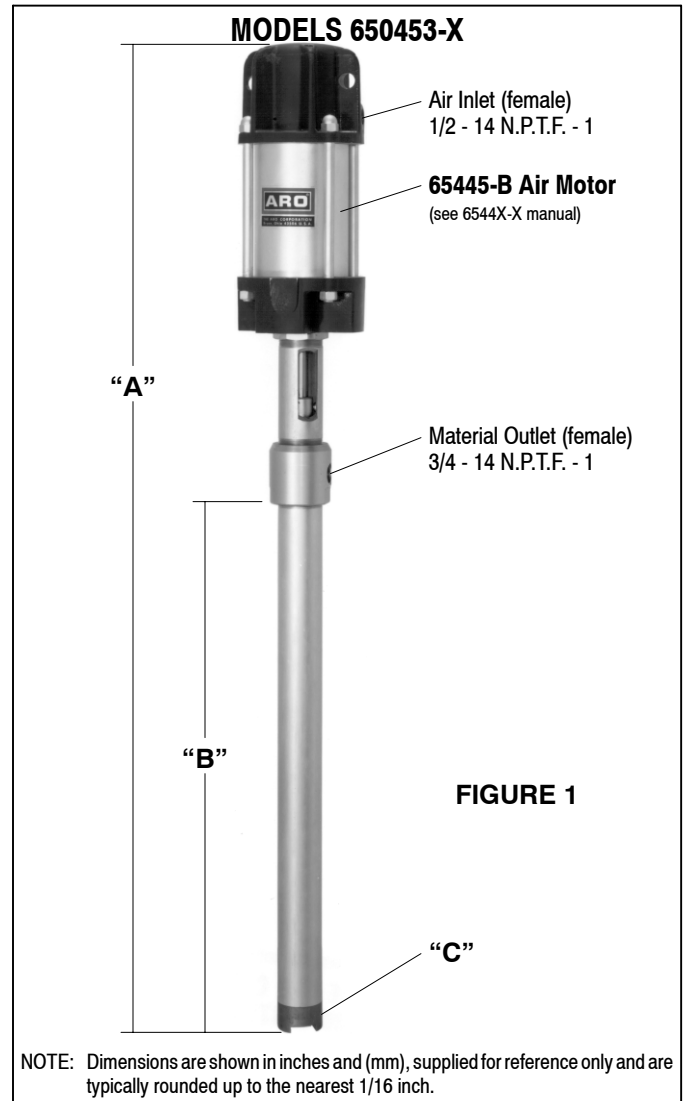

FIGURE 1

Model Number	Packing Material	Pump Type	"A"	"B"	"C"
650453-5	PTFE	55 gal	59-1/4"	37-1/8"	Immersed
650453-7	PTFE/Leather	Stub	32-11/16"	10-9/16"	1-1/2" NPT
650453-8	UHMW-PE	55 gal	59-1/4"	37-1/8"	Immersed
650453-9	UH / Leather	Stub	32-11/16"	10-9/16"	1-1/2" NPT
650453-10	UHMW-PE	Stub	32-11/16"	10-9/16"	1-1/2" NPT
650453-11	PTFE	Stub	32-11/16"	10-9/16"	1-1/2" NPT

- Disconnect air line from pump air motor when system sits idle for long periods of time.
- Materials and solvents being pumped by this pump must be compatible with the parts of this pump that come in contact with the material and solvent.
- **SERVICING.** Before servicing or cleaning pump, or removing fluid hose or gun from a unit that has been used, be sure to disconnect air lines and carefully bleed the pressure off the system.
- **WARNING: PREVENT STATIC SPARKING.** If static sparking occurs, fire or explosion could result. Pump, dispensing valve and containers must be grounded when handling inflammable fluids such as petroleum products, paints, lacquers, etc. and wherever discharge of static electricity is a hazard.
- Use grounded hoses (static wire) and be sure the object is grounded if it can produce a static charge.
- Check continuity (a good static wire connection) with an ohmmeter. Place one probe on one hose fitting and the other probe on other hose fitting, continuity or proper grounding through hose is good when a reading is obtained on the ohmmeter.
- **PREVENT FIRES.** When pumping, flushing or recirculating volatile solvents, the area must be adequately ventilated.
- Keep solvents away from heat, sparks and open flames. Keep containers closed when not in use.
- **CAUTION:** Do not allow pump to operate when out of material.

AIR & LUBE REQUIREMENTS

- Excessive air pressure will shorten the life of the pump. **DO NOT OPERATE PUMP ABOVE RECOMMENDED MAXIMUM AIR PRESSURE.**
- For maximum operating efficiency, the following air supply specifications should be maintained to this pump.
 - a) **AIR PRESSURE - up to 150 p.s.i. (10.3 bar)**
 - b) **AIR FILTRATION - 50 micron**
 - c) **LUBRICATED AIR SUPPLY**
 - d) **AIR INLET SIZE 1/2 - 14 N.P.T.F.**
- Filtered and oiled air will allow the pump to operate more efficiently and yield a longer life to operating parts and mechanisms.
- Lack of or an excessive amount of lubrication will affect the performance and life of this pump. Use only recommended lubricants.
- **DAILY** Fill air line lubricator reservoir with a good grade of S.A.E. NO. 90 W non-detergent gear oil, adjust to 1 to 2 drops per minute.
- If pump is to be inoperative for more than a few hours at a time, disconnect air supply and relieve all pressure from the system.
- It is recommended that an oiler be installed in the air line as close as possible to the pump. This increases the service life of the pump by reducing wear of the air motor's internal parts.

INSTALLATION

- The 650453-5 or -8 pump is to be mounted in the 2" bung of a 55 gallon drum.
- The 650453-7, -9, -10 or -11 pump is to be wall mounted. A 61113 pump mounting bracket may be used to mount pump to wall.

FLUSH PUMP

1. Connect fluid hose to pump outlet. Be sure all fittings are tight.
2. Turn air regulator knob counter-clockwise until it turns free.
3. Pump has been tested in oil and a small amount remains for protection against rusting. Immerse lower pump end in compatible solvent.
4. Connect air hose coupler to connector on Filter - Regulator - Lubricator.
5. Turn air regulator knob clockwise until air motor starts. Flush pump until oil is removed.
6. Disconnect air supply to air motor.

- **CAUTION:** Solvent used for flushing may not be compatible with material to be pumped. If this is the case, flush again with a compatible solvent.
- If pump is to be inoperative for an unspecified period of time, disconnect air and relieve all pressure.
- If pump does not function properly, disconnect air and relieve all pressure. Refer to "Trouble Shooting".

OPERATING INSTRUCTIONS

1. Turn air regulator knob clockwise until air motor starts to cycle.
2. Allow pump to cycle slowly until it is primed and all air is purged from the fluid hose or dispensing valve. Turn off dispensing valve and allow pump to stall - check all fittings for any leakage.
3. Change air regulator setting until desired pressure and flow is obtained.
4. Inspect air line filter, open petcock, to flush moisture or residue from bowl.
5. Pump is recommended to operate between 30 p.s.i. (2.1 bar) and 120 p.s.i. (8.3 bar) (not to exceed 75 cycles per minute).

MAINTENANCE

The basic pump consists of two major components: 1. Air Motor, 2. Lower Pump End. The air motor is connected to the lower pump end by a spacer section and solvent cup. The air motor is removable and is to be serviced separately. Refer to air motor manual for service and parts.

- Periodically flush entire pump system with a solvent that is compatible with the material being pumped.
- Keep solvent cup filled with this compatible solvent. This will keep material from drying on the piston rod, which would drag thru the packings, ruin them and eventually scour the piston rod.
- Refer to Disassembly Procedures of air motor for correct breakdown.
- Disassembly should be done on a clean work bench with clean cloths to keep parts clean.
- If replacement parts are necessary, consult drawing containing parts for identification.
- Before assembling, lubricate parts where required. When assembling "O" rings or parts adjacent to "O" rings, care must be exercised to prevent damage to "O" rings and "O" ring groove surfaces.

PUMP DISASSEMBLY

Special Tools:

- Strap wrench (PN 640081-B)
- Truarc retaining ring pliers (external)

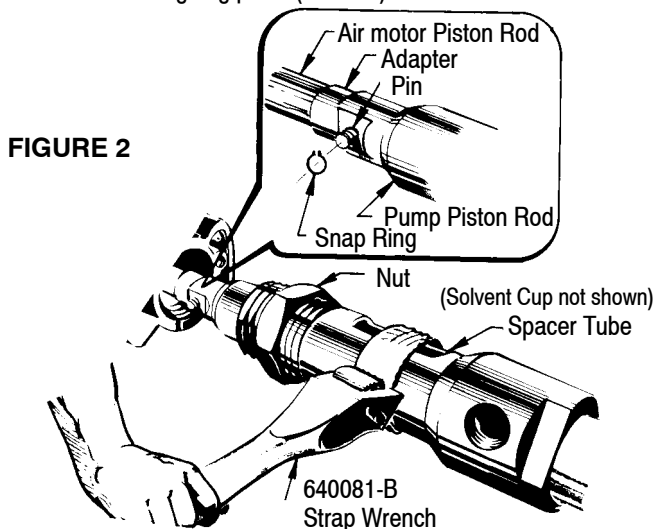
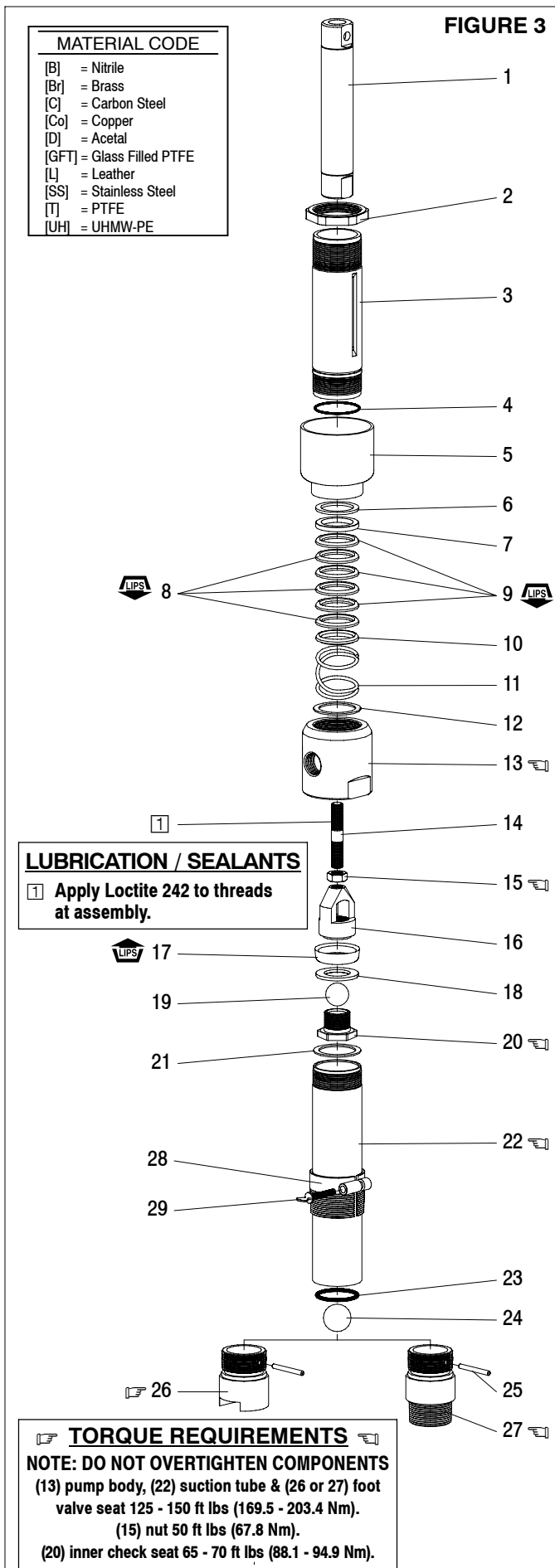

FIGURE 2

PARTS LIST / LOWER PUMP END



Item	Description (Size in inches)	Qty	Part No.	Mtl
1	Piston Rod	(1)	90584	[C]
2	Lock Nut	(1)	90571	[C]
3	Spacer Tube	(1)	90582	[C]
4	"O" Ring (1/16" x 2" o.d.)	(1)	Y325-32	[B]
5	Solvent Cup	(1)	91182	[C]
6	Washer	(1)	77432	[SS]
7	Female Packing Washer	(1)	77327	[D]
8	"V" Packing (650453-5, -11)	(3)	90578-2	[GFT]
	(650453-7, -9)	(3)	90578-1	[L]
	(650453-8, -10)	(3)	90578-4	[UH]
9	"V" Packing (650453-5, -7, -11)	(3)	90578-2	[GFT]
	(650453-8, -9, -10)	(3)	90578-4	[UH]
10	Male Packing Washer	(1)	91349	[D]
11	Spring	(1)	90120	[C]
12	Washer	(1)	90125	[Co]
13	Pump Body	(1)	90579	[C]
14	Piston Rod (650453-5, -8)	(1)	90642	[C]
	(650453-7, -9, -10, -11)	(1)	76507	[C]
15	Nut (1/2" - 20)	(1)	Y11-108-N	[C]
16	Cup Follower	(1)	75678	[C]
17	Cup (650453-5, -7, -11)	(1)	73919	[T]
	(650453-8, -9, -10)	(1)	92867-1	[UH]
18	Washer	(1)	94516	[C]
19	Ball (1" o.d.)	(1)	Y16-232	[C]
20	Inner Check Seat	(1)	75681	[C]
21	Washer	(1)	90125	[Co]
22	Suction Tube (650453-5, -8)	(1)	90641	[C]
	(650453-7, -9, -10, -11)	(1)	91116	[C]
23	"O" Ring (1/8" x 1-7/8" o.d.)	(1)	Y325-223	[B]
24	Ball (1-3/16" o.d.)	(1)	Y16-238	[C]
25	Ball Stop Pin (3/16" o.d. x 1-13/16")	(1)	90438	[SS]
26	Foot Valve Seat (650453-5, -8)	(1)	90119	[C]
27	Foot Valve Seat (650453-7, -9, -10, -11)	(1)	77006	[C]
28	Bung Adapter (includes item 29)	(1)	60870	[C]
29	Thumb Screw (1/4" - 20 x 1-1/2")	(1)	Y197-158-C	[C]
Service Kit			637177	

LOWER PUMP END TO AIR MOTOR SEAL DETAIL

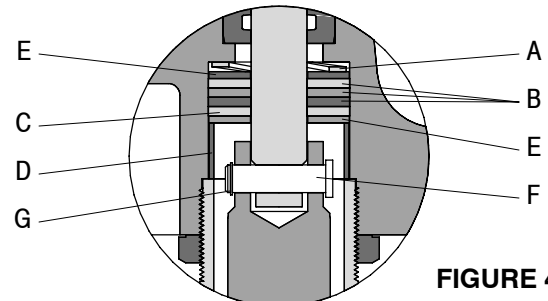

A	Wavy Spring Washer	(1)	90251	[C]
B	Packing	(3)	90567	[L]
C	Packing (650453-5, -8, -10, -11)	(1)	90643	[T]
	(650453-7, -9)	(1)	90567	[L]
D	Spacer	(1)	90570	[C]
E	Washer	(2)	90568	[Br]
F	Connector Pin	(1)	90572	[C]
G	Retaining Ring	(1)	Y145-2	[C]

SPECIAL INSTRUCTIONS

- _ Use flats on pump body for holding in vice to remove tubes.
- _ Be careful not to deform suction tube while removing.
- _ Do not mar finish on plunger.

NOTE: All threads are right hand.

1. Loosen (2) nut and use strap wrench or pipe wrench to unscrew (3) spacer tube from air motor base.
2. Pull lower pump end from air motor until (F) pin is exposed.
3. Use retaining ring pliers and remove (G) retaining ring from (F) pin. Remove (F) pin.
4. Pull lower pump end from air motor.
5. Pump reassembly is done in reverse order.

THEORY OF OPERATION

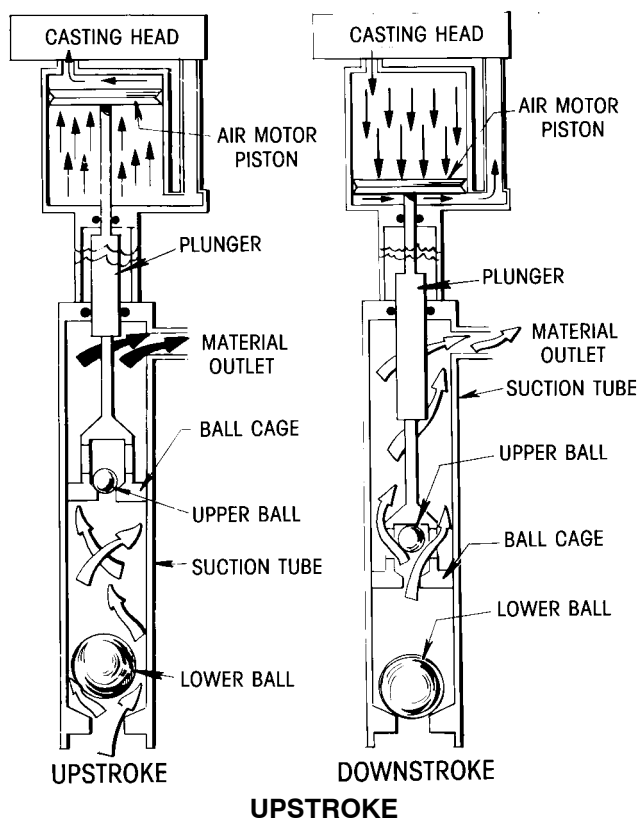

AIR MOTOR:

- Compressed air below air motor piston forces it up.
- Air above piston is exhausted.

LOWER PUMP END:

- Plunger moves upward in the suction tube.
- Upper ball is seated and material above piston ball cage (black arrows) fills the cavity left by the plunger and the excess is forced through material outlet.
- As piston moves up, suction created lifts lower ball from seat and suction tube is filled with more material (white arrows).

DOWNSTROKE

AIR MOTOR:

- Compressed air above air motor piston forces it down.
- Air below piston is exhausted.

LOWER PUMP END:

- Piston goes down causing lower ball to seat. Material in suction tube (white arrows) forces the upper ball from seat and flows through piston ball cage to the upper portion of the suction tube.
- Plunger enters suction tube causing displacement of material (black arrows) through material outlet.

TROUBLE SHOOTING

PROBLEM

- Air leakage out of slots in (3) spacer tube.

CAUSE

- Worn lower air motor packings.

REMEDY

- Replace packings (see figure 4).

PROBLEM

- No material (stalled pump).

CAUSE

- Obstructed material line.

REMEDY

- Remove obstruction.

PROBLEM

- No material (pump continually cycles).

CAUSE

- Empty material supply.

REMEDY

- Disconnect the air. Replenish material supply. Connect the air.

CAUSE

- Pin (F) disassembled from air motor piston rod.

REMEDY

- Reconnect air motor piston rod to (1) pump rod with (F) pin. Secure (F) pin with (G) retaining ring.

PROBLEM

- Material on one stroke only (fast downstroke).

CAUSE

- (24) ball in (26 or 27) seat is not seating.

REMEDY

- Remove the foot valve. Clean and inspect ball and foot valve. If either ball or foot valve is damaged, replace.

PROBLEM

- Material on one stroke only (fast upstroke).

CAUSE

- Worn (17) cup.

REMEDY

- Replace with new (17) cup.

PROBLEM

- Material leakage out slots in (3) spacer tube.

CAUSE

- Worn (8 or 9) packings.

REMEDY

- Replace with new (8 or 9) packings.